

Development of a Soil Bin Compaction Profile Sensor

M. Loghavi^{1*} and M. R. Khadem²

ABSTRACT

Development of sensors to detect the location and depth of hard pans in real time is a major restriction on the application of Site Specific Crop Management (SSCM). In this study, a soil compaction profile sensor equipped with four horizontal operating penetrometers for on-the-go sensing and mapping of the location and intensity of hard pans artificially formed in a soil bin was developed and tested. The leading edge of a 600 mm long vertical soil cutting blade held four 8 mm diameter, 80 mm long, and 30 degree conic tip stainless steel soil penetrating rods equally spaced at 100 mm vertical intervals. With this arrangement, when the cutting blade was driven into the soil up to a 500 mm depth, the conic tips sensed soil penetration resistances at 100, 200, 300 and 400 mm depths. The penetration resistance force was transmitted by the rod end to the elastic diaphragm of a hydrostatic oil chamber beneath each rod. Each oil chamber was connected to a force magnifying piston and cylinder located off the soil engaging tools. The penetration force was magnified five times before being sensed by a strain gage load cell. Software programs with the capability of discriminating 16 levels of soil compaction intensity were developed for monitoring soil impedances sensed by the soil probes and for converting them to soil compaction maps. For conducting the tests in the soil bin, the sensor mounted on the tool carrier frame was moved along the bin, where artificially formed compacted soil blocks with various densities (1.45, 1.65 and 1.85 Mg/m³) were placed at different locations and depths (up to 500 mm deep at 100 mm increments). While the probe was cutting and advancing through the soil, the corresponding compaction map was simultaneously displayed on a PC monitor, and the soil penetration resistance data of all four sensing tips was displayed and stored in program files.

Keywords: Compaction map, Hardpan, Sensor, Soil compaction profile.

INTRODUCTION

Precision farming or Site Specific Crop Management (SSCM) involves applying the right amount of crop production inputs based on crop requirements, taking into account the soil type and physical condition, fertility level, soil organic matter and moisture content (Robert *et al.*, 1992). The development of soil sensors to determine soil texture and conditions in real time is a major restriction to the application of SSCM (Gaultney, 1989). Soil mechanical impedance due to the formation of hard pans is one of the most important factors limiting crop

production, since it exerts significant constraints on seedling emergence, root and plant growth. Compaction resulting from heavy field traffic and tillage implements is the primary cause of hardpan formation. Subsoiling is used as the most effective method of alleviating compacted layers. A major problem with subsoiling is the large amount of energy that must be used to pull the subsoiler shanks through the soil. Tilling just deep enough to break up the hardpans is important to avoid expending excessive energy.

For characterizing soil mechanical impedance and determining the location and the depth of hardpans, a number of soil pene-

¹ Department of Agricultural Machinery, Shiraz University, Shiraz, Islamic Republic of Iran.

² College of Agriculture, Azad University of Eghlid, Eghlid, Islamic Republic of Iran.

*Corresponding author.



trometers have been developed and tested (Carter, 1967; Anderson *et al.*, 1980; Tollner and Verma, 1984), but they can only be used for vertical measurements at discrete points in a field. The stop-and-go insertion method means that continuous motion over the soil surface is not possible. Soil compaction levels estimated by using the ASAE standard cone penetrometer tend to be highly variable and often misleading in dry and cloddy soil conditions (1). Since soil mechanical impedance is one of the primary soil physical factors that should be closely monitored during or after tillage and planting operations, methods and techniques for its measurement from a moving vehicle should be developed (Alihamsyah *et al.*, 1990). The development of an instrument consisting of appropriate sensors mounted on a moving vehicle to continuously monitor soil physical factors was first proposed by Bowen and Coble (1967). Two prototype horizontal operating soil penetrometers, a prismatic tip and a conic tip, were developed and compared to a vertically operated ASAE standard soil cone penetrometer (Alihamsyah *et al.*, 1990). They showed that the soil penetration resistances recorded by the horizontal penetrometers were well correlated to those obtained by the ASAE standard vertical soil cone penetrometer. Hellebrand (1993) suggested the use of a horizontally moving cone penetrometer to measure soil texture. Glancey *et al.* (1989) developed an instrumented chisel and used it to predict tillage implement draft requirements in different soil types and conditions (Glancey *et al.* 1996). They found that draft requirement of this device depended on soil type, physical condition and strength properties. Draft data points contained high frequency variations related to the soil fracture phenomena as well as mechanical vibrations induced by tractor- implement combination and this data could not be used to predict soil texture and compaction level. Raper *et al.* (1990) used a non-contacting on-the-go technique to detect the depth of an artificially formed hardpan in a soil bin by utilizing a Ground-Penetrating Radar (GPR). They used a standard soil

cone penetrometer according to ASAE standard S313.2 (ASAE, 2002) to determine hardpan depth and compared it with GPR. Correlations between hardpan depths predicted by both methods were very linear. Further research could determine if this device can be used effectively in a wide range of soil types to detect hardpan depth. Sirjacobs and Destain (2000) designed and developed a soil mechanical resistance sensor for soil strength mapping and correlation with soil physical properties. Their soil probe was an instrumented thin blade, designed to measure soil forces and moments while it was pulled through the soil. This approach was claimed to provide a layer of information for precision agriculture.

Objectives

The objectives of this study were: 1. To develop a prototype load sensing and monitoring soil probe equipped with four horizontal operating penetrometers suitable for on-the-go sensing of soil impedance. 2. To produce a soil compaction map of artificially formed soil compaction levels in a soil bin.

MATERIALS AND METHODS

The experimental soil compaction profile sensor consisted of four primary parts: (1) a thin vertical soil cutting blade equipped with four cone tip rods and hydrostatic load sensing cells; (2) four strain gage load cells for converting applied force to electrical signals; (3) four microprocessors equipped with power source, amplifier and data processor for providing 10 V DC input voltage to the load cells and processing their output signals and (4) a personal computer (PC) with CPU, keyboard and monitor for the processing, control and display of a soil compaction map using GIS software. A schematic diagram of the experimental soil compaction sensing and monitoring system is shown in Figure 1.

The 600 mm long and 15 mm thick vertical soil cutting blade, acting as the soil compac-

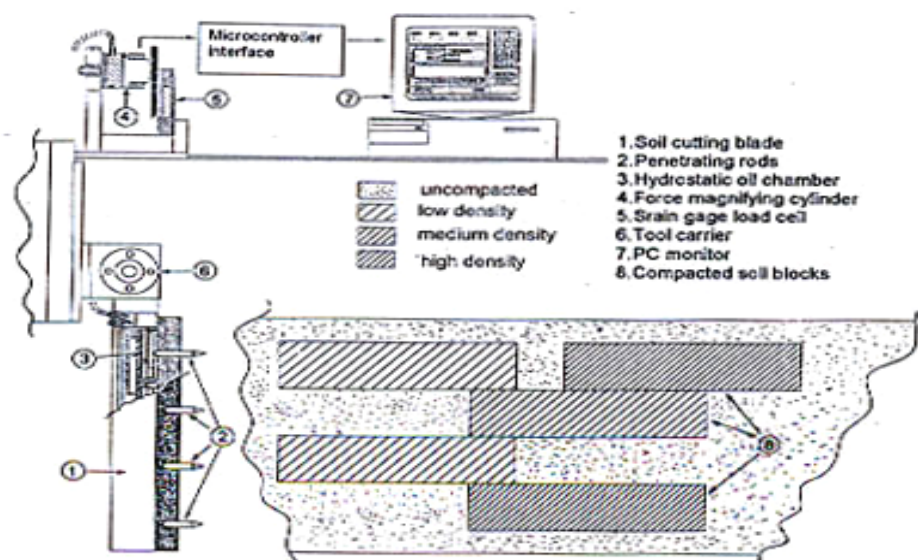

Figure 1. A schematic diagram of the experimental soil compaction profile sensing and mapping hardware.

tion sensing probe, was rigidly bolted to the tool carrier frame of the soil bin. Its leading edge was beveled and sharpened with an apex angle of 30 degrees to minimize soil disturbance and draft force. The leading edge held four 8 mm diameter, 80 mm long stainless steel horizontal soil penetrating rods (1) with a 30 degree apex angle cones spaced vertically at 100 mm from each other (Figure 2). With this arrangement, when the cutting blade was driven into the soil up to 500 mm depth, the conic tips sensed soil penetration resistances at 100, 200, 300 and 400 mm depths. The penetration resistance force was transmitted by each rod end to a pressure transfer bar (2) resting on the elastic diaphragm (3) of a hydrostatic oil chamber located behind each rod as shown in Figure 2. Each oil chamber (4) was a rectangular 100 × 15 × 10 mm cavity precisely cut in the blade main body and tightly covered and sealed by an oil resistant elastic membrane or diaphragm (3). Each oil chamber was connected to a force magnifying piston and cylinder as shown in Figure 3, located off the soil engaging tools, first through an oil gal-

lery (5) drilled through the blade body and then through a high pressure steel reinforced hosing (6). An elastic membrane (1) in close contact with the piston (2) prevented the possibility of any oil leakage, while the piston was loosely fitted to prevent friction and provide free floatation. By such an arrangement, the penetration force was magnified about five times before being sensed by a Tempo Model AA strain gage load cell (3) in contact with the convex head of the piston. Each of the four load cells used in the soil probe had a 300 N force capacity and was excited by a 10V dc power supply of the signal processing unit. A seven-segment digital display was connected to each load cell to monitor its output signals.

Data Storage and Processing

The data storage and processing unit consisted of two main parts: hardware and software. The hardware included all the physical components of the electronic control, and the software included the set of guiding commands of the control system. The inter-

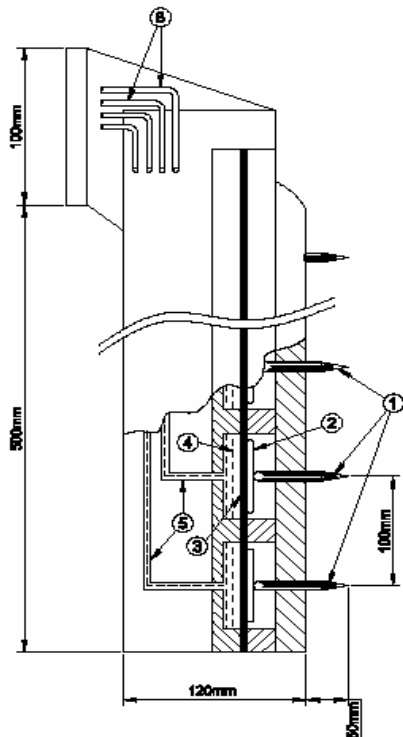

Figure 2. A schematic diagram of the soil cutting blade, showing the locations of the soil penetrating rods (1), pressure transfer bar (2), elastic diaphragm (3) and hydrostatic oil chamber (4).

face microcomputer between the soil probe and PC consisted of three primary parts: a 10V DC power supply, a load cell output signal amplifier, and a data acquisition and processing board.

A 80C31 microcontroller with four 8 bit I/O ports was used as the data acquisition and processing board. A 27128 EPROM with 10 kB memory was used for data storage. A 62256 RAM with 32 kB memory was used for temporary storage of load cells output data. A flow diagram of the soil compaction sensing and monitoring system is shown in Figure 4.

Three software programs (SIS2, SIS16 and SIS18) were written using C++ programming language for monitoring any soil impedances sensed by the soil probes and converting them to compaction maps. SIS2 was

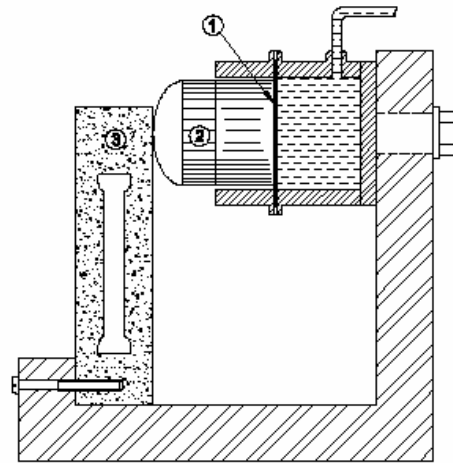

Figure 3. A schematic diagram of the force magnifying piston and cylinder, showing the locations of the elastic membrane (1), piston (2) and strain gage load cell (3).

used when only one penetrating cone sensed soil impedance and it had the capability of discriminating 6 levels of soil resistance intensity. SIS16 had the same level of resolution as SIS2, but could support data from four active penetrating cones simultaneously. SIS18 was suitable when four compaction sensors were active, but it had the capability of discriminating 16 levels of soil compaction intensity. A typical display of the main computer program page is shown in Figure 5. On this page there are several icons to select, such as "File", "Print", "Set color", "Show data" etc. For example, by selecting "Print" two options are available; one displaying a resistance profile (map) and the other displaying a resistance diagram at any selected point. By selecting "Set color", various compaction intensities can be discriminated by selecting different colors based on the color scale displayed on the page. By selecting "Show data", a table showing resistance data can be accessed. Description of the specifications and capabilities of other selections is beyond the scope of this article.

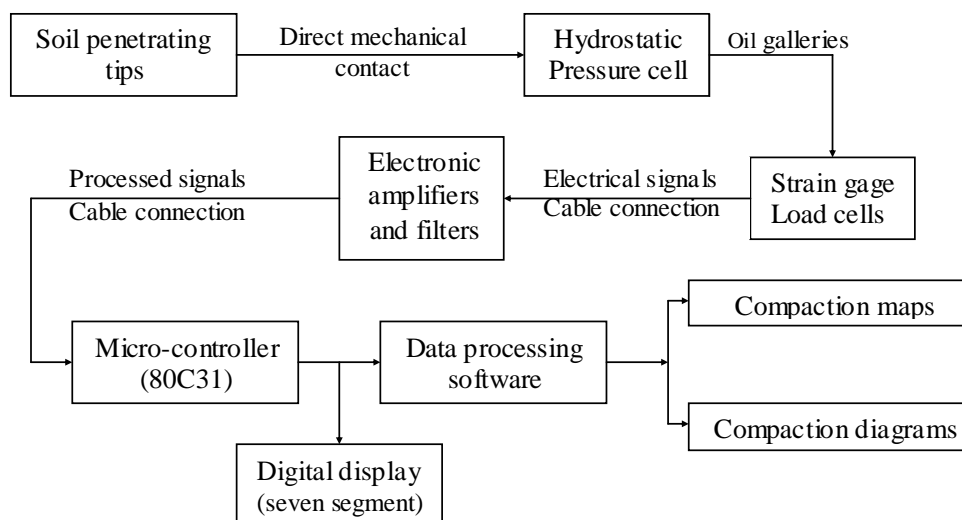

Figure 4. Soil compaction sensing and monitoring system flow diagram.

Sensor Test and Evaluation

Since all components of the soil compaction sensor were new prototypes designed and developed for this study, each component was first tested independently and then the complete system was tested. For testing and calibration of the soil impedance sensors, a special loading test rig was designed

and built. A schematic diagram of this test rig showing its components is given in Figure 6. A hydrostatic oil chamber (4) similar to the ones employed in the main body of the cutting blade, behind each soil penetrating rod, was used as a force to pressure transducer. The loading platform (13) was mounted on top of the vertical loading rod (12) which transferred the gravitational force

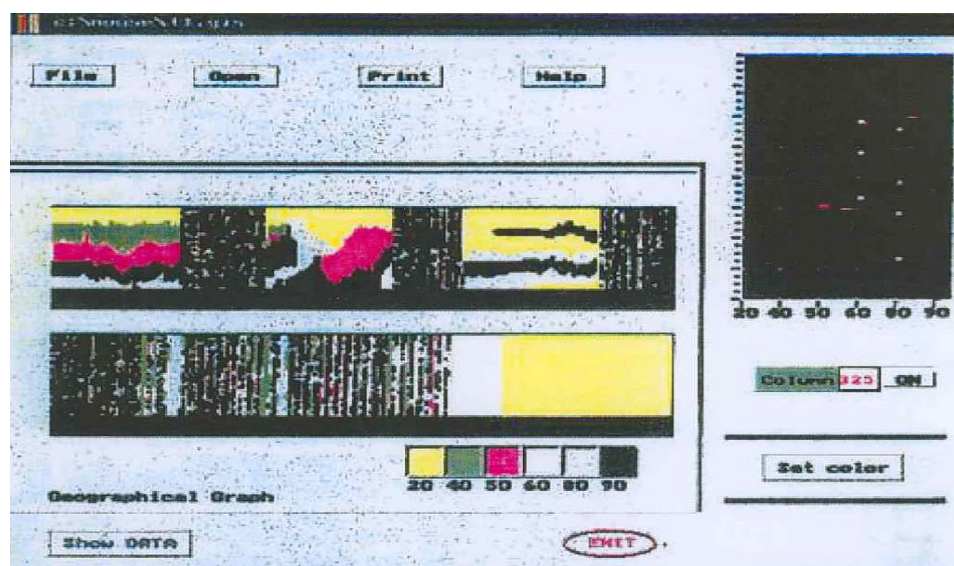

Figure 5. A typical display of the main program page showing soil compaction profile (map) and other available selections.

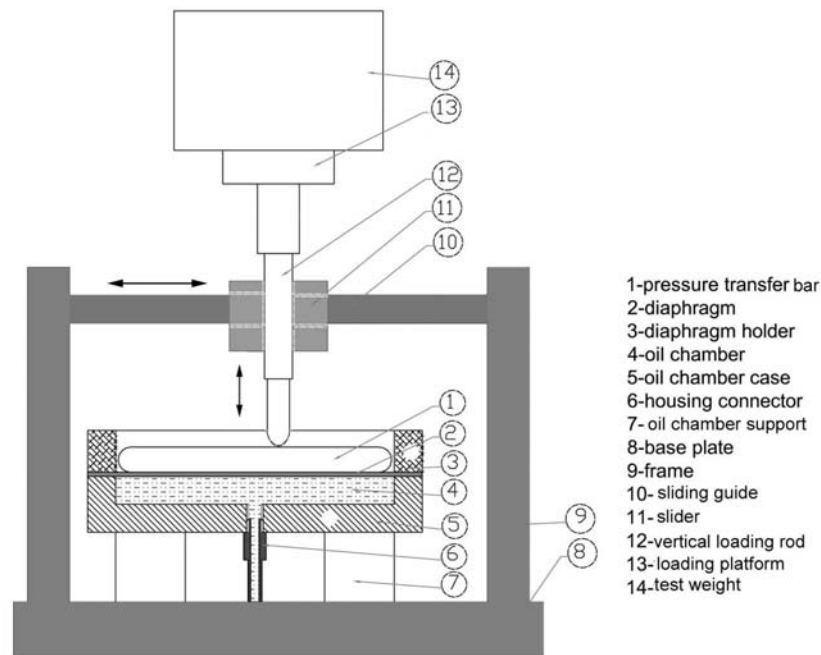

Figure 6. A schematic diagram of the loading test rig.

of any desired test weight (14) resting on the loading platform to the oil chamber through the pressure transfer bar (1) resting on the oil chamber diaphragm. This pressure transfer bar was also used in the soil compaction probe to convey the soil penetration force to the pressure cell uniformly. The loading bar (12) and the platform (13) could be moved laterally to apply the gravitational force of the test weight (14) at any point along the pressure transfer bar (1). For providing this lateral movement, the slider guide (11) holding the vertical loading bar (12) was riding on two parallel frictionless guide bars (10). With this arrangement, it was possible to test the performance characteristics of the soil resistance sensors, such as linearity, repeatability, and response time. This test rig was connected in turn to each of the four force magnifying cylinders and load cells to test their performance (Figure 7). Also, the computer software SIS16 was used to monitor the response of the hardware of all four sensors to predetermined external loads. By adding various known weights on the load-

ing platform, the hydrostatic pressure cell and, consequently each strain gage load cell, was loaded and calibrated. In this rig and also in the soil probe, a steel bar was used in contact with the diaphragm to convey the penetration force to the pressure cell uniformly.

For testing the sensing performance of the probe, three types of test were conducted. First, for evaluating the sensor response time a 3 kg weight was suddenly applied on the loading platform of the test rig. By plotting the sensor output vs time, the response time between the point that loading curve started to rise to the point that it started to level off (transition period) was calculated as the response time of the sensor. Second, for confirming that sensor response was independent of the point of load application, the probe output was monitored and compared, while the loading platform carrying a 3 kg weight was located at three different points—first, at the middle of the guide bars, then 40 mm to the right and 40 mm to the left of the center. Finally the loading platform was



Figure 7. The test rig connected to one of the four force magnifying cylinders and its load cell to test their performance.

moved at various velocities along the guide bars, while the sensor output was monitored and compared.

Testing the Soil Compaction Sensor in the Soil Bin

For conducting this stage of the evaluation process, the fully assembled soil probe was mounted on the tool carrier frame of the soil bin. Two types of probe evaluation tests were conducted in the soil bin; a preliminary test and a final test. In the preliminary test, only the soil in a part of the 8 m long soil bin was compacted by a steel roller in order to form a compacted zone in the soil. The compacted layer was about 250 mm deep. Therefore, only one of the four sensing tips of the soil probe was left active. The aim of the preliminary test was to find out if the soil probe could be able to sense and map the compacted layer. The working depth of the probe was adjusted such that its active sensor tip worked at 150 mm below the soil surface.

The aim of the final test was to sense and map hardpans with various densities and strengths located at different locations and depths. In order to form predefined hardpans in the soil bin, compacted soil blocks ($500 \times 500 \times 100$ mm) molded outside the soil bin with low (1.45 Mg/m^3), medium (1.65 Mg/m^3), and high density (1.85 Mg/m^3), were buried horizontally in the soil bin at various depths (up to 500 mm deep at 100 mm increments) and configurations as shown in Figure 8. The soil bin internal dimensions were; 8 m long, 1.5 m wide and 0.6 m deep and it was filled with a light textured sandy loam soil.

In both preliminary and final tests, before starting to cut the soil the lateral and vertical positions of the soil probe were adjusted by moving the probe to the desired coordinate point by activating the corresponding electric motors of the tool carrier frame. Then the probe carrier was translated along the soil bin at the desired speed (0.5 m/s) by the probe carrier longitudinal drive motor. While the probe was cutting and advancing through the soil, the soil compaction map

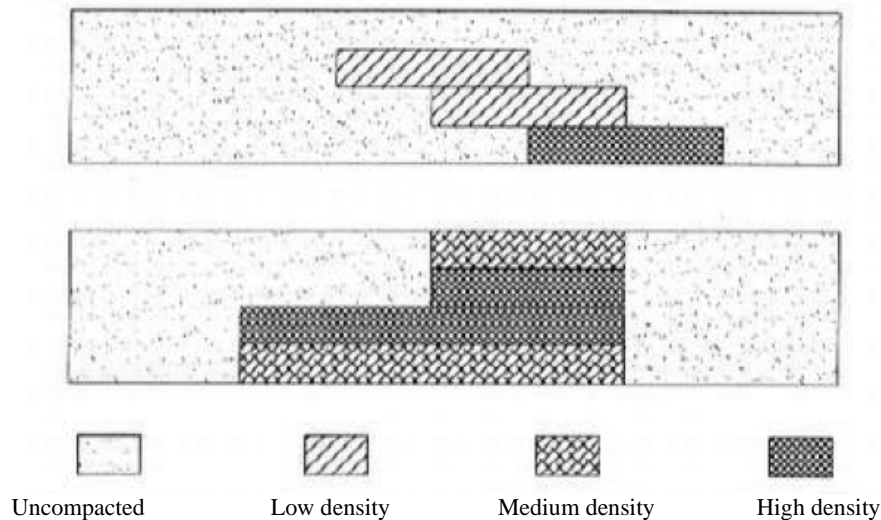

Figure 8. Soil blocks compacted at various densities located at various depths and configurations in soil bin.

was simultaneously displayed on the PC monitor and the complete penetration data of all four sensors were stored in program files.

RESULTS AND DISCUSSION

Results of the Soil Probe Evaluation Tests

Figure 9 shows a colored band representing the intensity of load applied on the probe pressure cell. The green part of the band indicates the existence of a low permanent pressure in the pressure cell confined oil before applying any external load. The red portion of the band enclosed by yellow borders represents the sensor response to the 5 kg weight exerted on the loading platform of the sensor test rig. As the colored band develops gradually as a linear function of time (full span development of a colored band takes 120 seconds), the length of the red band represents the duration of time that 5 kg weight was applied on the sensor. The width of the yellow border on the left side of the red band represents the time response of the sensor hardware to a step function external load. The variation of the sensor output

(load index) vs. time for exerting the 5 kg weight on the sensor is plotted in Figure 10. This figure shows that the transition response period is about 0.9 second long. The results showed that the response of the soil compaction sensor to a sudden change in soil impedance did not follow a step function, but a linear or non-linear one that it took about 0.9 second for the sensor response to reach a steady state.

In order to find out which part of the soil sensing and monitoring system is mainly responsible for this response time, in another test, the hydrostatic part of the sensor was removed and the external load was applied



Figure 9. Colored band representing the intensity of applied load on the probe pressure cell.

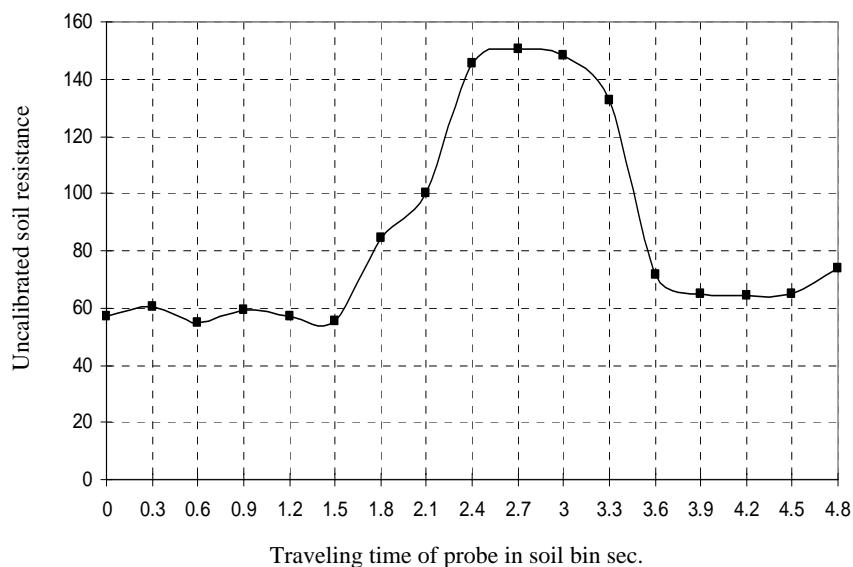

Figure 10. Variation of sensor output vs. time, showing its response to a suddenly applied load.

directly to the strain gage load cell. The resulting output showed that the change of color on the output map was quite sudden and also the output curve was a step function (Figure 11). Comparing Figure 10 and 11, the delay in sensor response was mainly due to the use of the hydrostatic part of the soil compaction sensor. In fact, transmission of force signals by the fluid was much slower than its transmission through the electronic

circuits after it was converted to the equivalent voltages. Also, some high frequency signals were damped by the hydraulic sensors due to the viscous nature of the hydraulic fluids. This shock and high frequency dampening property could be an advantage in soil cutting probes due to the cyclic fracture phenomena occurred in compacted soils.

The colored band representing the response

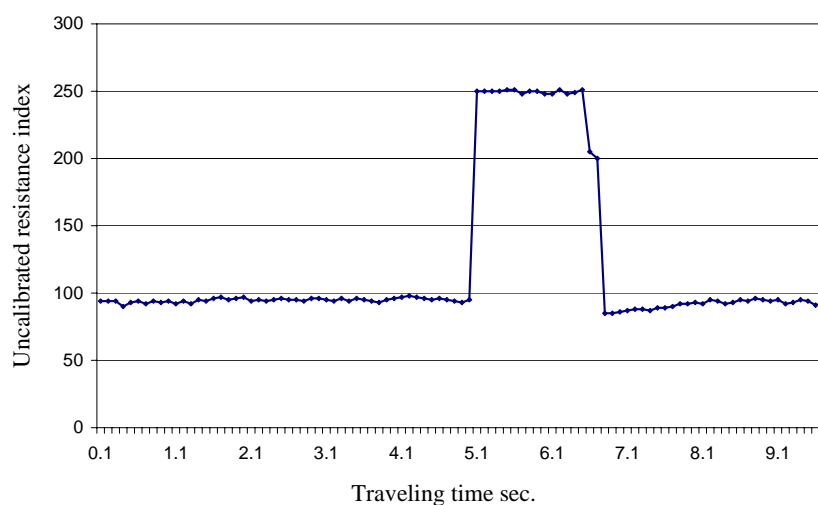

Figure 11. Variation of strain gage output vs. time, showing its response to a suddenly applied load.

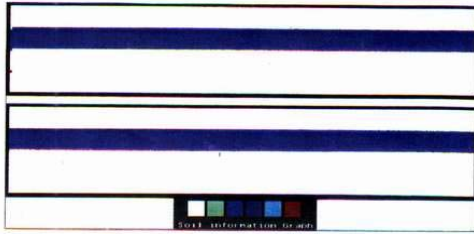

Figure 12. The uniformly colored (blue) band indicates that the sensor response is independent of the point of load application.

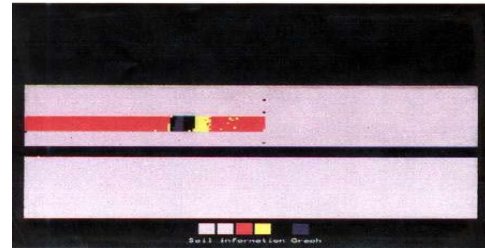

Figure 13. The colored band representing a local compaction in the soil bin.

of the applied load (3 kg weight) exerted at three different locations along the guide bars appeared with the same color (medium blue), regardless of the point of locating the 3 kg weight (Figure 12). This result indicated that the soil compaction sensor was able to sense and transmit soil impedance regardless of where its soil penetrating tip was located with respect to the pressure cell.

The results of sensor evaluation tests conducted using a constant load (3 kg weight) moving at three different velocities (0.8, 1.5 and 4.6 cm/s) showed that the pressure sensed by the probe and displayed on the PC screen as a blue colored band did not change at the different velocity levels tested. This result indicated that the soil compaction sensor could be used with either

stationary or moving penetrating tips (passive or active) along the vertical cutting blades in order to sense soil impedance discretely or continuously at various depths.

Results of the Soil Compaction Sensor Test in the Soil Bin

The soil compaction map of the preliminary test as displayed on the monitor is shown in Figure 13. Variation of the sensor output which represents sensor tip penetration resistance vs. its longitudinal translation through the soil is plotted in Figure 14. Both figures show that the soil probe has sensed the compacted layer by sending the relevant resistance measurement signals to the image processing unit, where test data have been

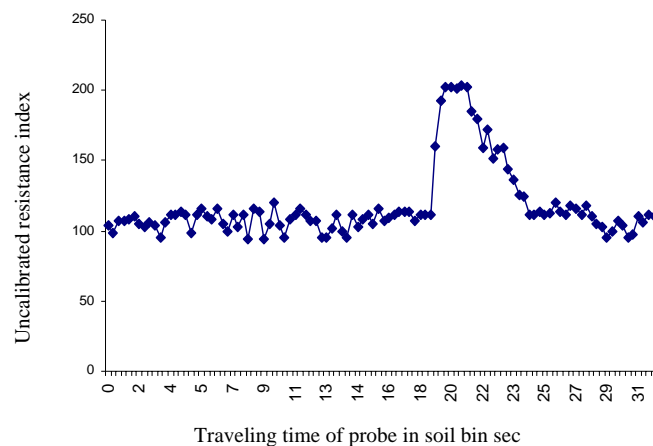

Figure 14. Variation of sensor tip penetration resistance vs. its longitudinal translation along the soil bin in the preliminary test.



Figure 15. Soil compaction map of the hard pan configuration arranged in the soil bin as shown in Figure 8.

processed and displayed by appropriate software on a PC monitor. No definite explanation could be given regarding the sudden rise and gradual fall of the compaction curve in Figure 14 because the compacted zone in the soil bin was formed by several passes of a roller and consequently did not have any well defined boundary.

The soil compaction map of the final test in the soil bin as displayed on the monitor is shown in Figure 15. In this test, the speed of data processing was adjusted such that the speed of the image development and display on the monitor was equal to the speed of the probe advancement in the soil bin. In other words, an accurate timing between the probe speed and the rate of data transfer and processing was maintained throughout the test. So, the soil compaction map displayed on the monitor was dimensionally similar to the hardpan configuration arranged in the soil bin. Figure 15 shows that the variably compacted soil blocks buried in the soil bin (Figure 8) have been detected and displayed as discriminable colors at their proportionate locations. So, we may conclude that the soil compaction sensing and monitoring probe

can be used successfully to detect and monitor hardpans on-the-go in real time.

In practical applications, the soil compaction sensor could be mounted on the front of a tractor performing subsoiling operations in a field. The soil probe could then provide soil compaction data to a microcomputer as an integral part of a control system for automatic adjusting of subsoiling depth. It is recommended that further research be conducted in soil bins and also under field conditions with additional variations of forward speed and soil type and condition. Also, the effects of cutting blade geometry and rake angle, and sensor tip shape and location on soil compaction sensing and monitoring should be evaluated.

ACKNOWLEDGMENT

This research was conducted at Shiraz University as a part of the project No. 511 funded by the National Research Council.



REFERENCES

1. Alihamsyah, T., Humphries, E. G. and Bowers Jr., C. G. 1990. A technique for horizontal measurement of soil mechanical impedance. *Trans. of the ASAE*, **33(1)**: 73-77.
2. Anderson, G., Pidgeon, J. D Spence. H. B. and Parks, R. 1980. A new hand- held recording penetrometer for soil studies. *J. Soil Sci.* **31**: 279 - 296.
3. ASAE Standards, 49th Ed. 2002. S313.2. Soil Cone Penetrometer. ASAE. St. Joseph, MI.
4. Bowen, H. D. and Coble, C. G. 1967. Environmental requirement for germination and emergence. *Trans. of the ASAE*, **11(12)**: 10-24.
5. Carter, L. M. 1967. Portable recording soil penetrometer measures soil strength profiles. *Agricultural Engineering*. **48(6)**: 348 - 349.
6. Gaultney, L. D. 1989. Precision farming based on soil property sensors. ASAE Paper No. 89 - 1036. ASAE, St. Joseph. MI. 49085.
7. Glancey, J. L., Upadhyaya, S. K., Chancellor, W. J. and Rumsey, J. W. 1989. An instrumented chisel for the study of soil-tillage dynamics. *Soil and Tillage Research*, **14**: 1-24.
8. Glancey, J. L., Upadhyaya, S. K., Chancellor, W. J. and Rumsey, J.W. 1996. Prediction of implement draft using an instrumented analog tillage tool. *Soil and Tillage Research*, **37 (1)**: 47-65.
9. Hellebrand, H. J. 1993. Trends in sensors for spatially variable control of field machinery. ICPPAM Paper No. 93-1075. 5th International Conference on Physical Properties of Agricultural Materials (ICPPAM). Sep. 6-8, Bonn, Germany.
10. Raper, R. L., Asmusen, L. E. and Powell, J. B. 1990. Sensing hard pan depth with Penetrating Radar (GPR). *Trans. of the ASAE*, **33(1)**: 41-46.
11. Robert, P. C., Rust, R. H. and Larson, W. E. 1992. Adapting Soil- Specific Crop Management to today 's farming operations. A workshop on Research and Development Issues. April 14-16. Minneapolis, MN 19p.
12. Sirjacobs, D. and Destain, M. F. 2000. A soil mechanical resistance sensor for on-line application in precision agriculture: soil strength mapping and correlation with soil physical properties. Proceedings of the AgEng 2000 Conference, Warwick, UK.
13. Tollner, E. W. and Verma, B. P. 1984. A modified cone penetrometer for measuring soil mechanical impedance. *Trans. of the ASAE.*, **27(2)**: 331 - 336.

طراحی و ساخت یک حسگر نیمرخ فشردگی در انبار خاک

م. لغوی و م.ر. خادم

چکیده

ساخت حسگرهایی به منظور تشخیص موقعیت و عمق سخت لایه‌ها در زمان حقیقی تنگنایی در بکارگیری مدیریت خاص مکانی تولید محصولات زراعی محسوب می‌گردد. در این تحقیق یک حسگر نیمرخ فشردگی خاک مجهز به چهار عدد فروسنج افقی کار برای تشخیص و تهیه نقشه موقعیت و شدت فشردگی در حال حرکت سخت لایه های بطور مصنوعی ایجاد شده در یک انبار خاک طراحی. ساخت و ارزیابی گردید. تعداد چهار عدد میله فروسنج نوک مخروطی با زاویه راس 30 درجه از جنس فولاد ضدزنگ به قطر 8 و طول 80 میلی متر بطور افقی و به فاصله 100 میلی متر از یکدیگر بر روی لبه جلو

یک تیغه عمودی برش خاک به طول 600 میلی متر سوار گردید. با این ترکیب زمانی که تیغه تا عمق 500 میلی متری در خاک حرکت داده شد، نوک های مخروطی مقاومت نفوذ در خاک را در عمق های 100، 200، 300 و 400 میلی متری حس نمودند. این نیروی مقاومت نفوذ توسط انتهای میله به دیافراگم ارتجاعی یک محفظه هیدروستاتیکی روغن واقع در زیر هر میله انتقال می یافت. هر محفظه روغن به یک سیلندر و پیستون تقویت نیرو غیر واقع بر روی ادوات درگیر با خاک مرتبط بود که نیروی مقاومت نفوذ را قبل از حس شدن توسط یک نیروسنج از نوع کرنش سنجی حدود پنج برابر بزرگنمایی می نمود. برنامه های نرم افزاری با قابلیت تفکیک 16 سطح شدت فشردگی خاک برای آشکار سازی مقاومت حس شده توسط میله های فروسنج و تبدیل آنها به نقشه های فشردگی نوشته شد. برای اجرای آزمون های درون انباره خاک، در حالی که بلوک های خاک بطور مصنوعی فشرده شده با تراکم های مختلف (1/45، 1/65 و 1/85 تن در متر مکعب) در موقعیت ها و عمق های مختلف خاک (تا عمق 500 میلی متر با گام های 100 میلی متری) قرار داده شده بود، حسگر نصب شده بر قاب حامل ادوات، در طول انباره حرکت داده شد. در حالی که تیغه در حال برش و پیشروی در خاک بود، بطور همزمان نقشه نیمرخ فشردگی خاک بر روی صفحه نمایشگر رایانه نشان داده می شد و داده های هر چهار میله فروسنج در پرونده های مربوطه ذخیره می گردید.