

Resistance to Air Flow across a Thin Green Fig Bed

Y. Amanlou^{1*}, and A. A. Zomorodian¹

ABSTRACT

Green fig, which is usually consumed as dry fruit, is one of the important non-oil export agricultural commodities of Iran. In this study, some important physical properties of green figs including geometric mean diameter, sphericity, porosity, particle and bulk density and pressure drop across a thin bed were measured at constant moisture content of 6% (dry basis). Air flow ranges used in this study were 0.4-1.0 m³ s⁻¹ m⁻² at three temperatures. The fig kernels were put together in thin layers in four different arrangements. The effect of filling methods and air flow rates on pressure drop were highly significant, while the air temperature did not show any appreciable effect on air flow resistance. Three applicable and most versatile models (Shedd, Hukill and Ives, and Ergun) were used to evaluate the pressure drop data. The Ergun model, with higher values of coefficient of determination (R²= 0.989) and lower value of root mean square error (RMSE= 21.84) and mean relative deviation modulus (P%= 6.69), was selected to be the best model for predicting pressure drop across green figs thin layer bed for the conditions studied.

Keywords: Filling arrangement, Ergun model, Physical properties, Pressure drop.

INTRODUCTION

Green fig (*Ficus carica* L.) is one of the favorite dried fruits in the world. This horticultural product is grown mostly in Iran, Turkey, and Afghanistan and has been one of the important non-oil agricultural export commodities of Iran in the last three decades. It is widely used in confectionery, snack foods, and pastry industries (Doymaz, 2005).

When air flows through a porous bed of materials like agricultural products, its pressure will drop. To recover the pressure drop, applying a fan is necessary and the energy demand for running the fan depends highly on the imposed pressure drop. In any drying process, inattention to the relationship between air velocity, bed type, moisture content, bed depth, filling method, and channel characteristics of the porous bed can result in excessive water loss, shrinkage, and quality degradation and can cause large pressure drops that would require more powerful fan systems.

However, lower air flow rates result in increasing product temperature and risk of insect infestation. When storing in bins, it is necessary to maintain previously dried figs at uniform and sufficiently low temperature to avoid mold growth and other undesirable biochemical reactions. The prediction of air flow resistance in a selected bed of agricultural material has been studied widely for more than 70 years. Comprehensive studies on the effect of different factors such as air flow rate, bed type, moisture content of bulk, bed depth, filling method, amount and type of foreign materials, and direction of air flow through the bulk have been conducted on grains and other agricultural products. The effects of the above mentioned parameters on air flow resistance have been closely reviewed for a number of materials including: grains (Shedd, 1951 and 1953; Hukill and Ives, 1955; Jayas *et al.*, 1987; Sokhansanj *et al.*, 1990; Li and Sokhansanj, 1994; Dairo and Ajibola, 1994; Giner and Denisenia, 1996; Chung *et al.*,

¹ Department of Agricultural Engineering, Shiraz University, Shiraz, Islamic Republic of Iran.

* Corresponding author, e-mail: y.amanlou@yahoo.ie



2001), parchment Arabica coffee (Agullo and Marenya, 2005), chickpea (Masoumi and Tabil, 2003), apples and chicory roots (Verboven *et al.*, 2004), rape (Patil and Ward, 1988), compost (Barrington *et al.*, 2002), and pistachio nuts (Kashaninejad and Tabil, 2009).

Freshly harvested green figs must be dried and stored prior to supplying to the market. Knowledge about the air flow resistance across a bed of green figs is one of the most crucial requirements for many fig post harvesting unit operations such as drying, cooling, and control of optimal storage conditions. These unit operations have been usually studied at two bed depth conditions: thin and thick layers. In the present investigation, pressure drop was studied across a thin green fig bed since such data have not been reported in the available literature. The objectives of this study were the followings:

To measure the important physical properties of kernel and green fig bed which are dependent on particle arrangements (particle density, bulk density and porosity).

To investigate the effect of air flow rate, bed channel characteristics, and air temperatures on static pressure drop across a bed of fig.

To determine the appropriate mathematical model for pressure drop prediction across a fig thin layer bed.

MATERIALS AND METHODS

Samples Preparation

The green figs used in this study were purchased from a local market in 2007. Foreign materials were all removed by hand. The moisture contents of the figs were determined by oven-drying the samples at $100\pm 0.5^\circ\text{C}$ until constant weights were reached (Kashaninejad and Tabil, 2009). The initial moisture content of the product was 6% (db). All experiments were conducted at this initial moisture content.

Experimental Apparatus

To measure air flow resistance across the bed of figs, a test rig was designed and fabricated in the Department of Agricultural Engineering, Shiraz University, Iran. The main parts of the test rig are illustrated in Figure 1. A constant speed centrifugal fan (Parma, 1,400 rpm, 50 Hz, Italy) was used as an air flow source. A damper was inserted into the fan outlet to alter the air flow rate. The air flow velocity was measured using a hot wire anemometer (Lutron, Taiwan) in a PVC pipe (15 cm ID.) connected to the plenum chamber (15 cm ID.) connected to the plenum chamber.

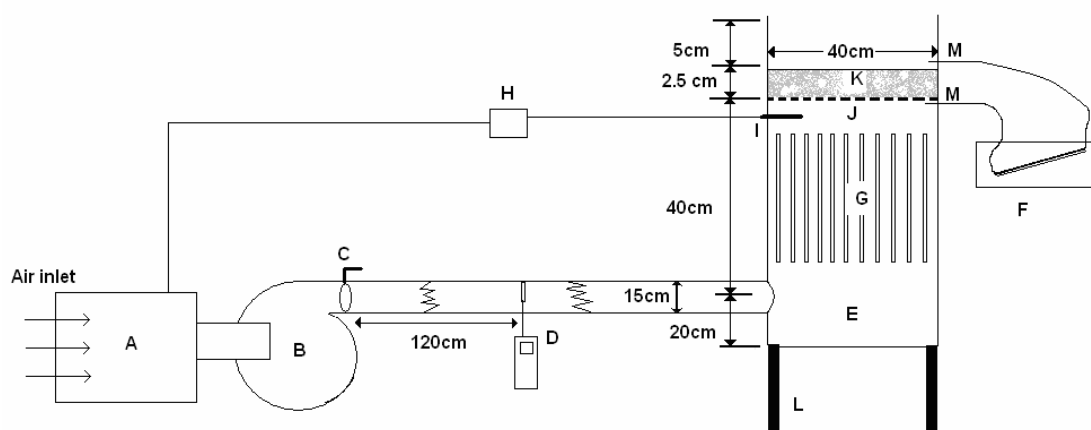

Figure 1. Schematic diagram of the apparatus used for air flow resistance measurement of green figs. (A) Electrical heating unit; (B) Centrifugal fan; (C) Damper; (D) Hot wire anemometer; (E) Plenum chamber; (F) Manometer; (G) Air flow straightener; (H) Thermostat; (I) Thermostat sensor; (J) Screen floor; (K) Figs holding chamber, (L) Stand, (M) Pressure taps.

In order to have accurate air velocity measurements, the hot wire probe was inserted into a fully developed air stream in the air duct at 150 cm far from the fan exit. In each set of the air velocity measurements, five symmetrical point readings were recorded and the mean value of these readings was considered as the air flow velocity for that given condition. The air flow velocities were converted to air flow rates by multiplying the velocity by inside air duct cross section area. The plenum chamber and figs holding chamber were made of a smooth PVC pipe with 40 cm inside diameter. The figs in the container were supported by a perforated stainless sheet of metal placed at the bottom of the figs holding chamber. Inlet air temperature to the fig bed was precisely controlled by a thermostat sensor hanging just before the air was introduced into the fig bed (at bin, $\pm 0.1^\circ\text{C}$, Iran). An electrical heating unit (6 kW) was attached to the fan inlet regulating the air temperature introduced into the fig bed. The pressure drop was measured by an accurate inclined manometer (Tecequipment, British pat: 771493, $\pm 1 \text{ mm H}_2\text{O}$), Figure 1.

Depth of Fig Bed and Filling Methods

In this study, the kernels were put together in four arrangements, X, Y, Z (Figure 2) and random arrangement in the fig holding chamber. Due to special shape of the fig kernel the channel characteristics formed by these arrangements in the porous bed would be different and it was believed that the

voids shape and size in the different bed arrangements may show some influence on bed pressure drop.

Determination of Physical Properties of Fig

Fifty kernels of figs were picked up randomly from a bulk of figs to determine dimensions and sphericity. Three principal dimensions, length (L), width (W) and height (H) were measured by a caliper (Mitutoyo, Japan, $\pm 0.05 \text{ mm}$). The geometric mean diameter (GMD) and sphericity (ϕ) of fruits and nuts were calculated by the following equations (Mohsenin, 1996):

$$GMD = (LWH)^{\frac{1}{3}} \quad (1)$$

$$\phi = \frac{(LWH)^{\frac{1}{3}}}{L} \quad (2)$$

Porosity of a given bulk of material has a tangible effect on air flow resistance. Therefore, the porosity, fig particle density (ρ_p), and bulk density (ρ_b) were measured. Kernel density of fig is the mass per unit volume of a single fig. The particle density of dry fig was measured using the liquid displacement method. Toluene was used instead of water because it has low surface tension so that it fills even shallow dips in a dry fig and its dissolution is negligible (Mohsenin, 1996).

The bulk density of three different

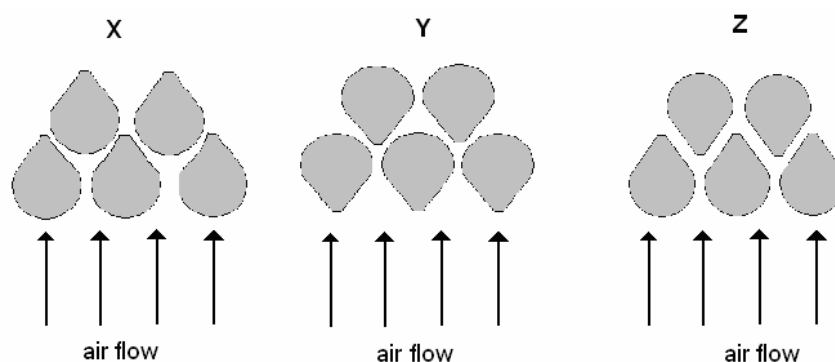

Figure 2. Three different arrangements used for filling thin layer bed in the fig holding chamber.



arrangements X, Y, Z and random free fill (loose bed) were calculated from the mass and volume of the circular container with known volume filled with samples. The porosity (ε) of the bulk fig was determined using the following equation (Mohsenin, 1996):

$$\varepsilon = 1 - \frac{\rho_b}{\rho_t} \quad (3)$$

Experimental Procedure

During the experiments, room temperature was recorded as $20 \pm 2^\circ\text{C}$ and relative humidity was in the range of $30 \pm 5\%$. The pressure drops across a thin layer (2.5 cm depth) of green figs (6% db initial moisture content) for four different arrangements used for filling the chamber were measured (Figure 2).

Mathematical Modeling

Several models have been reported in the literature to foresee pressure drop across grain and other agricultural material beds. The oldest and most famous model used is the Shedd model (Shedd, 1951; 1953).

$$Q = A_1(\Delta P)^{B_1} \quad (4)$$

One important drawback of the Shedd model is that it can be used to predict the air flow resistance only over a narrow range of air flow rates ($0.005\text{--}0.3 \text{ m}^3 \text{ s}^{-1} \text{ m}^{-2}$) due to non-linearity of the log-log plot. The reciprocal of A_1 in this equation represents the resistance to air flow through the product. Physically, the reciprocal of A_1 in the equation was used to compare resistance to air flow of different samples (Kashaninejad and Tabil, 2009). All of the Shedd's measurements were made in columns of grain in which the air moved in paths parallel to the chamber axis. The model constants A_1 and B_1 depend upon moisture content and bulk density of the given grains. His study included different grains and his results did not show precisely

the effect of the bin's wall surface on air flow (Shedd, 1953). The Shedd model was recommended by Kashaninejad and Tabil (2009) for pistachio nuts. It was also suggested by Sokhansanj *et al.* (1990) for lentils and finally Jekayinfa (2006) used this model for locust bean seed.

Hukill and Ives (1955) proposed their equation for improved Shedd measurements. Their equation had a good fitness with Shedd's equation but it was not easy to use because the equation could not determine the pressure as a direct function of air flow rates (Pabis *et al.*, 1998). The Hukill and Ives model is used in standard D272.3 of the American Society of Agricultural and Biological Engineers (ASABE) to represent the air flow pressure drop data of selected grains (Kashaninejad and Tabil, 2009). Hukill and Ives equation is valid over a wide range of air flow rates, $0.01\text{--}2 \text{ m}^3 \text{ s}^{-1} \text{ m}^{-2}$ (Hukill and Ives, 1955). Agullo and Marenja (2005) recommended Hukill and Ives model for parchment Arabica coffee. Sokhansanj *et al.* (1990) reported a good data fitting result for the Hukill and Ives model compared to Shedd model for lentils. The equation is in the form of:

$$\Delta P = \frac{A_2 Q^2}{\ln(1 + B_2 Q)} \quad (5)$$

The third and more versatile empirical equation is the Ergun model (1952). The Ergun equation is based on fluid-dynamic principles (Kashaninejad and Tabil, 2009). Ergun model includes the influence of the porosity, particle diameter, air density, and viscosity. According to his equation, the total energy loss in a packed bed should be treated as the sum of the viscous and kinetic energy losses. His original equation is shown below (Garg and Maier 2006):

$$\Delta P = \frac{A\mu(1-\varepsilon)^2}{GMD^2\varepsilon^3} Q + \frac{B\rho(1-\varepsilon)}{GMD\varepsilon^3} Q^2 \quad (6)$$

A and B in Ergun's equation are dimensionless empirical constants. At the given environmental condition and product, air viscosity (μ), air density (ρ), porosity of bed (ε) and geometric mean diameter

(GMD) are constants. For simplicity of use, factors other than air flow rate can be lumped in two parameters for each agricultural material, (Giner and Denisienia, 1996; Hunter, 1983). Therefore, the Ergun equation is simplified to:

$$\Delta P = A_3 Q + B_3 Q^2 \quad (7)$$

Since the physical properties of the fluid and the product were considered in the Ergun equation, more realistic results could be expected.

Kashaninejad and Tabil (2009) reported that the Shedd model yielded higher value for the coefficient of determination (R^2) and lower values for mean square error (MSE) and mean relative deviation modulus (P%). Agullo and Marenia (2005) reported the same results for Shedd and Hukill and Ives models. Giner and Denisienia (1996) reported that the Ergun equation showed a better result compared to the Hukill and Ives equation; however, both models presented lower error values compared to the Shedd equation. Madamba *et al.* (1994) reported that the resistance to air flow through garlic slices could be characterized by the Ergun equation. This equation has been used successfully to describe the air flow resistance through granular materials (Patterson *et al.*, 1971; Bern and Charity, 1975).

In the present study, the air flow resistance experimental data were used to fit against three important models i.e. Shedd, Hukill and Ives and Ergun, using non-linear regression analysis (Microsoft Excel, solver, 2003). Several statistical criteria such as coefficient of determination (R^2), root mean square error (RMSE) and mean relative percentage deviation modulus (P %) were used to evaluate the goodness of fit. The best model describing the air flow resistance of

green figs was chosen as the one with the highest coefficient of determination and the least root mean square error and mean relative deviation modulus (Snedecor and Cochran, 1989; Kashaninejad and Tabil, 2009).

RESULTS

Physical Properties of Green Figs

The principle dimensions (L, H and W), the geometric mean diameter, kernel density and sphericity of a 50-kernel sample were measured. The averages of length (L), height (H), and width (W) were 20.7 mm, 19.7 mm, and 20.3 mm, respectively. The average GMD of the sample was calculated as 20.1 mm. The sphericity and kernel density magnitudes were 92% and 1068 kg m⁻³, respectively.

The bulk density and porosity of the bed for the three channel arrangements X, Y, Z and the random filling using a discharge tube with zero height of fall for charging the bin (loose bed) are shown in Table 1.

Pressure Drop Experimental Results

The effect of channel characteristics arrangements (X, Y and Z), air flow rates, and air temperatures on pressure drop of the thin layer green figs were studied at initial moisture content of 6 % db. Four levels of air flow rates (0.4, 0.6, 0.8 and 1 m³ s⁻¹ m⁻²) and air temperatures of 30, 35 and 40°C were established. Pressure drop was considered as a dependent variable and a factorial completely randomized design analysis method was selected for investigating the

Table 1. Physical properties of the green figs.

Filling methods	Bulk density (kg m ⁻³)	Porosity (%)
X	524	51
Y	485	55
Z	530	50
Random filling	527	51



effect of different variables on air flow resistance. MSTAT-C (version 2.10) statistical package was used for statistical analysis. The results are presented in Table 2.

The effects of filling methods and air flow rates on pressure drop were highly significant. The air temperature did not show any significant effect on air flow resistance. This may be due to the fact that the air physical properties (μ and ρ) showed very minor changes over the experimental air temperature (30-40°C), Table 2.

The results showed that in the Z arrangement, the air flow resistance was greater than X and Y, with the minimum amount in the case of Y (Figure 3). These variations can be attributed to the shape of air flow canals made by putting the fig

kernels together in thin layer with different arrangements and ease of air flow entrance to the thin layer bed (Figure 2). Besides, the porosity of the Y filling method was higher than those of X and Z. The higher the porosity the less is the air flow resistance (Mohsenin, 1996). Thus, in the Z filling method, the average air flow resistance was 14% higher than that of Y. For a given filling method, the air flow resistance increases with an increase in air flow rate. It can be seen that this increasing trend is more or less similar for all the filling methods with variable slope (Figure 3).

The estimated product-dependent coefficients and comparison of statistical criteria for the three air flow resistance models (Shedd, Hukill and Ives, and Ergun) for the thin layer pressure drop experimental

Table 2. Effects of filling methods, temperatures and air flow rates on pressure drops of a thin layer of green figs.

Variables	Degrees of freedom	Sum of squares	F value
Filling method (A)	2	40405	5.55**
Temperature (B)	2	7512	1.03
A×B	4	196106	13.47**
Air flow rate (C)	3	535596	49.07**
A×C	6	169799	7.78**
B×C	6	40340	1.85
A×B×C	12	24304	0.56
Error	72	261969	

** Significant at $P=0.01$

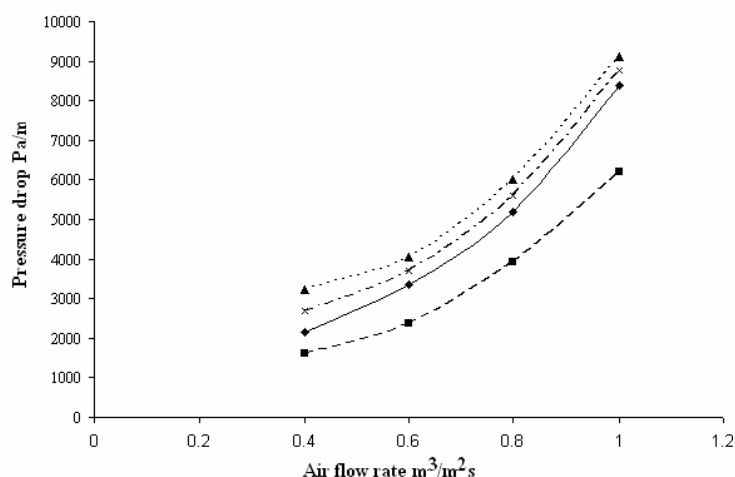

Figure 3. Effect of filling method on pressure drop of thin layer dry green figs at moisture content of 6 (db%) ♦, X; ■, Y; ▲, Z; ×, random.

Table 3. Estimated product-dependent coefficients and comparison criteria for the three models (Shedd, Hukill and Ives, and Ergun) at different filling methods for thin layer bed of figs.

Model name	Filling method	A_1	B_1	R^2	RMSE	P%
Shedd	X	167.65	1.48	0.987	19.23	9.90
	Y	103.62	1.75	0.983	23.78	19.98
	Z	183.07	1.44	0.983	23.88	15.95
Hukill		A_2	B_2			
	X	206.20	3.11	0.987	19.63	6.63
	Y	366.82	96.69	0.987	24.39	8.29
Ergun	Z	185.30	1.95	0.984	23.39	6.86
		A_3	B_3			
	X	107.90	61.47	0.991	19.58	6.56
	Y	42.60	63.87	0.989	23.75	6.72
	Z	124.66	60.44	0.989	23.21	6.79

data of figs at different experimental conditions. The curve fitting results showed that the Ergun model could predict the pressure drop more precisely (highest R^2 , lowest RMSE and P% values) for the three filling methods of X, Y and Z as compared to the Shedd and Hukill and Ives models (Table 3).

CONCLUSIONS

The important physical properties of fig were measured: The principle dimensions (L, H and W), the geometric mean diameter, particle density and sphericity of a fig kernel were found to be: 20.7, 19.7, and 20.3, 20.1 mm, 1,068 kg m⁻³ and 92%, respectively. The bulk density of the bed for three channel arrangements X, Y, Z and random filling (loose bed) were 524, 485, 530 and 527 kg m⁻³, respectively, with the corresponding porosity values of 51, 55, 50 and 51%.

In pressure drop experiments, the effect of filling methods and air flow rates on pressure drop were highly significant, while the air temperature did not show any appreciable effect on air flow resistance. The results showed that in the Z arrangement, the air flow resistance was greater than X and Y, with the minimum amount in the case of Y.

The curve fitting results showed that the Ergun model could predict the pressure drop

more precisely (highest R^2 and least values for the RMSE and P% in comparison to the other models).

Nomenclature

A, B	Constants
A_1, A_2, A_3	Product-dependent coefficient
B_1, B_2, B_3	Product-dependent coefficient
L	Length (mm)
W	Width (mm)
H	Height (mm)
Φ	Percentage of sphericity
ρ	Air density (kg m ⁻³)
μ	Air viscosity (m ² s ⁻¹)
GMD	Geometric mean diameter (mm)
ρ_t	Kernel density (kg m ⁻³)
ρ_b	Bulk density (kg m ⁻³)
ϵ	Porosity
R^2	Coefficient of determination
RMSE	Root mean square error
P%	Mean relative percentage deviation modulus
Q	Air flow rate (m ³ s ⁻¹ m ⁻²)
ΔP	Pressure drop (Pa m ⁻¹)

REFERENCES

1. Agullo, J. O. and Marenia, M. O. 2005. Air Flow Resistance of Parchment Arabica Coffee. *Biosystems Eng.*, **91**(2): 149-156.



2. ASABE Standards. 2007. ASAE D272.3 MAR1996 (R2007) : "Resistance to Air flow of Grains, Seeds, Other Agricultural Products, and Perforated Metal Sheets". American Society of Agri. and Biological Eng., St. Joseph, MI, **54**: 627–633.
3. Barrington, S., Choiniere, D., Trigui, M. and Knight, W. 2002. Compost Air Flow Resistance. *Biosystems Eng.*, **81(4)**: 433-441.
4. Bern, C. J. and Charity, L. F. 1975. Air flow Resistance Characteristics of Corn as Influenced by Bulk Density. ASAE Paper, No. 75-3510, ASAE, St. Joseph, MI.
5. Chung, D. S., Maghirang, R. G., Kim, Y. S. and Kim, M. S. 2001. Effects of Moisture and Fine Material on Static Pressure Drops in a Bed of Grain Sorghum and Rough Rice. *Transactions of the ASAE*, **42(2)**: 331–336.
6. Dairo, O. U. and Agibola, O. O. 1994. Resistance to Air Flow of Bulk Sesame Seed. *Agri. Eng.*, **(58)**: 99-105.
7. Doymaz, I. 2005. Sun Drying of Figs: An Experimental Study. *J. Food Eng.*, **71**: 403-407.
8. Ergun, S. 1952. Fluid Flow through Packed Columns. *Chemical Eng. Progress*, **48**: 89-94.
9. Garg, D. and Maier, D. E. 2006. Modeling Non-uniform Airflow Distribution in Large Grain Silos Using Fluent. *9th International Working Conference on Stored Product Protection*, 15 to 18 October 2006, Brazil, PS7-12 – 6158.
10. Giner, S. A. and Denisienia, E. 1996. Pressure Drop through Wheat as Affected by Air Velocity, Moisture Content and Fines. *J. Agri. Eng. Research*, **63**: 73–86.
11. Hukill, W. V. and Ives, N. C. 1955. Radial Air Flow Resistance of Grains. *Agri. Eng.*, **35(5)**: 332-335.
12. Hunter, A. J. 1983. Pressure Difference across an Aerated Seed Bulk for Some Common Duct and Store Cross-sections. *J. Agri. Eng. Research*, **28**: 437–450.
13. Jayas, D. S., Sokhasanj, S., Moysey, E. B. and Barber, E. M. 1987. Air Flow Resistance of Canola (Rapeseed). *Transactions of the ASAE*, **30(5)**: 1484–1488.
14. Jekayinfa, S. O. 2006. Effect of Air flow Rate, Moisture Content and Pressure Drop on the Air flow Resistance of Locust Bean Seed. *Agriculture Engineering International. CIGR Ejournal*.
15. Kashaninejad, M. and Tabil, L. G. 2009. Resistance of Bulk Pistachio Nuts (Ohadi variety) to Air Flow. *J. Food Eng.*, **90**: 104-109.
16. Li, W. and Sokhasanj, S. 1994. Resistance of Bulk Alfalfa Seed to Air Flow. *Canadian Agricultural Eng.*, **36(1)**: 25–28.
17. Madamba, P. S., Driscoll, R. H. and Buckle, K. A. 1994. Bulk Density, Porosity and Resistance to Air Flow of Garlic Slices. *Dry. Technol.*, **12(4)**: 937–954.
18. Masoumi, A. A. and Tabil, L. 2003. Vertical Air Flow Resistance of Chickpea (*C. arietinum*) Cultivars as Affected by Moisture Content. *The Canadian Society for Engineering in Agricultural, Food, and Biological Systems*, No. 03-325.
19. Mohsenin, N. N. 1996. Physical Characteristics. In: "*Physical Properties of Plants and Animal Materials*". Gordon and Breach Science Publishers, Canada, PP. 79-127.
20. Pabis, S., Jayas, D. S. and Cenkowski, S. 1998. Resistance to Air Flow through Grains and Oilseeds. In: "*Grain Drying: Theory and Practice*". Ed.2, John Wiley and Sons, New York, PP. 229-246.
21. Patil, B. G. and Ward, G. T. 1988. Resistance to Air Flow of Oilseed Rape. *Agri. Eng.*, **(41)**: 25-31.
22. Patterson, R. J., Bakker-Arkema, F. W. and Bickert, W. G. 1971. Static Pressure-air Flow Relationships in Packed Beds of Granular Materials such as Grains II. *Transactions of the ASAE*, **14**: 172–174, **178**: 627–633.
23. Shedd C. K. 1951. Some New Data on Resistance of Grains to Air Flow. *Agri. Eng.*, **32**: 493-495
24. Shedd C. K. 1953. Resistance of Grains and Seeds to Air Flow. *Agri. Eng.*, **34(9)**: 616–619.
25. Snedecor G. W. and Cochran W. G. 1989. *Statistical Methods*. Iowa State University Press, USA. PP335.
26. Sokhasanj, S. A., Falacinski, A. A., Sosulski, F. W., Jayas, D. S. and Tang, J. 1990. Resistance of Bulk Lentils to Air Flow. *Transactions of the ASAE*, **33(4)**: 1281–1285.
27. Verboven, P., Hoang, M. L., Baelmans, M. and Nicolai, B. M. 2004. Air Flow through Bed of Apples and Chicory Roots. *Biosystems Eng.*, **88(1)**: 117-125.

مقاومت جریان هوا در یک بستر لایه نازک انجیر سبز

ی. امانلو و ع. ا. زمردیان

چکیده

انجیر سبز یکی از اقلام مهم صادرات غیر نفتی ایران است که به طور معمول به صورت خشک مصرف می شود. برخی از خواص فیزیکی مهم انجیر (میانگین هندسی اقطار، کرویت، تخلخل بستر، جرم حجمی دانه ای و جرم حجمی توده ای) و افت فشار در لایه های نازک این محصول در رطوبت اولیه ۶٪ بر پایه خشک اندازه گیری شد. در این تحقیق محدوده جریان هوای مورد استفاده بین ۰/۴-۱/۰ $(m^3 s^{-1} m^{-2})$ در سه دمای هوای مختلف بوده است. دانه های انجیر در چهار چیدمان مختلف (X ، Y ، Z و حالت تصادفی) در بستر لایه نازک قرار داده شدند. اثر چیدمان انجیرها و نرخ عبور جریان بر افت فشار بسیار معنی دار بوده در حالی که تغییرات دما بر افت فشار اثر معنی داری نداشته است. برای پیش بینی افت فشار در لایه های نازک انجیر سبز سه مدل مطرح و مهم به نام های شد، هوکیل-ایوز و ارگان مورد ارزیابی قرار گرفت. مدل ارگان با بیشترین ($R^2 = 0.989$) و کمترین ($RMSE = 21.84$) و $P\% = 6.69$) به عنوان بهترین مدل برای پیش بینی افت فشار در بستر لایه نازک انجیر سبز در شرایط مورد آزمایش انتخاب گردید.