

## Photoacoustic Technique Applied to the Assessment of the Dosage of a NPK Fertilizer in Maize (*Zea mays* L.)

F. Gordillo-Delgado<sup>1,2\*</sup>, D. H. Zapata-Sarmiento<sup>1</sup>, and A. Bedoya<sup>1</sup>

### ABSTRACT

The photosynthetic activity of maize plants (*Zea mays* L.) grown at different concentrations of a synthetic NPK fertilizer was evaluated and compared to explore an effective dosage criterium. The plants were grown under greenhouse conditions in a sterile medium to ensure controlled provision of nutrients. The Stomatal Density (SD) and Stomatal Index (SI) of the plants were estimated through micrograph analysis; while the rate of oxygen evolution, the absorption spectral curves, and the thermal diffusivity of the plant leaves were measured using the Photoacoustic Technique. The results regarding photosynthetic activity and thermal diffusivity indicated an oscillatory pattern of behavior during the growth period, and the characteristics of these oscillations were affected by the application of the NPK fertilizer. The photoacoustic spectroscopy analysis served to show that the treatment with the highest dosage of NPK fertilizer caused a decrease in the absorption of the chlorophyll *a* and *b*. Based on the results, the proposed methodology and used technique could have practicality in monitoring quantifiable variables to evaluate the influence that a fertilizer has on plants such as maize, which allows the determination of appropriate dosage.

**Keywords:** Fertilizer overuse, Photoacoustic spectroscopy, Photosynthesis, Stomatal density.

### INTRODUCTION

Nowadays, there are great controversies surrounding conventional agricultural techniques that use NPK fertilizers, since these practices produce long-term environmental damage caused by the excessive use of nutrients. Frequently, high doses of NPK fertilizers are applied and the remaining fertilizer is lost, leached from the soil and polluting water tributaries (Liu *et al.*, 2014; Sarwar *et al.*, 2010). Therefore, it is necessary to know the exact dosage to avoid the excessive use of these agrochemicals. In the present work, the pattern of Oxygen Evolution Rate (OER) of maize plants (*Zea mays* L.) was obtained through Photoacoustic (PA) technique to study the photosynthetic activity

in relation to the fertilizer dosage.

The PA is a nondestructive *in situ* method used to detect changes in the gas production, directly from the leaf in the photochemical process (Gordillo-Delgado and Botero-Zuluaga, 2020). This technique consists of acoustic waves generated from a body impinged with modulated light (Rosencwaig and Gersho, 1976). After the absorption of this radiation, a non-radiative de-excitation process produces periodic heating and the consequent variations under the pressure of air or gas in contact with the body surface. If photochemical activity simultaneously takes place, the periodic production of gases also contribute to these pressure changes in a region adjacent to the surface of the sample.

<sup>1</sup> Applied Science Research Group for the Development of the Eco-Region (GICADE) assigned to Interdisciplinary Institute of Sciences, University of Quindío, Armenia – Quindío, Colombia.

<sup>2</sup> Program of Electronic Instrumentation Technology of Faculty of Basic Science and Technology, University of Quindío, Armenia, Colombia.

\* Corresponding author; e-mail: fgordillo@uniquindio.edu.co



This sound is detected by an electret microphone, transversally communicated with a cylindrical chamber, over which the sample is placed (Marín, 2008). In this arrangement, called resonant close PA cell, this chamber must be hermetically closed with the leaf as a top, in order to avoid other pressure changing sources (Gordillo-Delgado *et al.*, 2016; Mandelis and Hess, 1997); unlike an open cell configuration, in which the sample is placed directly on the microphone (Acosta-Avalos *et al.*, 1996; Mesquita *et al.*, 2006). Both configurations have been widely used in studies of plant photosynthesis, reflecting the versatility of the PA technique.

In this work, some maize plants were treated with different doses of a NPK fertilizer and its effect was analyzed through OER in photosynthesis, Thermal Diffusivity ( $D_{TH}$ ) of the leaves and leaves content of chlorophyll. These parameters were measured using the PA technique with a closed PA cell (Barja *et al.*, 2001; Gordillo-Delgado 2016; Herbert *et al.*, 2006; Mandelis and Hess, 1997). Additionally, the variations of the stomatal organelles in the leaves were evaluated through an anatomical study using optical microscopy.

## MATERIALS AND METHODS

The maize plants were treated with different doses of a chemical NPK fertilizer and observed continuously. The oxygen produced during photosynthesis was monitored and the spectroscopic analysis provided information about the content of the pigments in the plants (Barja *et al.*, 2001; Herbert *et al.*, 2006;

Malkin *et al.*, 1990).

## Plant Growth

The growth process of maize seedlings (*Zea mays* L) started from the germination of yellow ICA V-305 variety seeds, provided by the Colombian Agricultural Institute (ICA). The plants were sown in pots and grown in a greenhouse located at the University of Quindío (Armenia, Quindío, Colombia), applying different concentrations of NPK granular nutrient dissolved in water for each treatment. The greenhouse was maintained at relative humidity between 68% and 74% and average temperature of  $26\pm 2^{\circ}\text{C}/12$  hour's day and  $16\pm 2^{\circ}\text{C}/12$  hour's night. Maize seeds were germinated on wet paper (Rao *et al.*, 2007).

## Treatment

Ten maize plants per treatment were treated with a NPK fertilizer composed of 25% Urea, 54% Diammonium Phosphate (DAP), and 21% Nitrogen-Phosphorus- Potassium granulated (Triple 15-VitaAgro); these are composition of a prepared mixture of 3 commercial fertilizers. The mixture of these products was dissolved in distilled water at four concentrations: 0.256, 0.382, 0.510 and 0.688  $\text{g mL}^{-1}$ , close to the dose recommended by the manufacturers for field application, which was estimated to be 0.510  $\text{g mL}^{-1}$  per plant (Bushong *et al.*, 2018; Rop *et al.*, 2018). The properties of applied NPK fertilizer are

**Table 1.** N, P, K composition and pH values of the applied fertilizer. Number of plants for each treatment. n=10.

Dose concentration ( $\text{g mL}^{-1}$ )	pH	N (g)	P (g)	K (g)
0.256	6.92	0.03	0.03	0.015
0.382	6.87	0.042	0.042	0.021
0.510	6.80	0.06	0.06	0.03
0.688	6.78	0.078	0.078	0.04

shown in Table 1, according to a report of the National Federation of Coffee Growers of Colombia (Moreno-Berrocal *et al.*, 2008).

## Experimental Assembly

### Photoacoustic Technique Applied to the Plant Leaves

The experimental setup used for *in situ* and *in vivo* detection of PA signal generated by the leaf is illustrated in Figure 1, using a homemade closed PA cell constructed from an aluminum block, in a well-known configuration (Gordillo-Delgado *et al.*, 2020). The plant leaf was adhered to the top of the cylindrical chamber (diameter 5 mm, length 5 mm) of the PA cell using commercial plasticine. This was done in a way that the abaxial view of the leaf was in contact with the enclosed air within this cylindrical chamber and the other side directly received a periodic train of light pulses from a red LED (625±20 nm, 1W). This radiation was selected because the chlorophyll pigment in the leaf absorbs this wavelength in high proportion during the photosynthesis process (Yousef *et al.*, 2021).

When pulses of light impinge on the leaf surface, a part of the radiation is absorbed and diffused through the leaf generating periodic pressure changes inside the cell, due to a process of conversion of thermal energy into acoustic energy, which are

detected by an electret microphone coupled to the PA cell cylindrical chamber. Consequently, the microphone transduces the pressure changes (acoustic waves) into an electrical signal composed of two contributions: (1) The photothermal response resulting from the conversion of the absorbed light energy into heat due to non-radiative de-excitation process, and (2) The photobaric response that occurs when the leaf, a photochemically active sample, periodically generates oxygen through the stomata in response to the light absorption, which produces an additional pressure change in the PA cell cavity.

The PA signal was recovered using a Lock-in Amplifier SR830, which utilizes the incident light modulation frequency as reference for filtering. The continuous white illumination on the opposite side of the PA cell is used for saturating the photosynthesis process.

The photosynthetic activity was monitored on maize seedlings for 20 days after germination. Thus, the *in vivo* measurement of OER was accomplished on each randomly selected plant, in the morning after being subjected to dark conditions for an acclimatization period of one hour to ensure that the leaf was in a stable state of photosynthetic metabolism (Bilger and Bjorkman, 1990). Each measurement lasted 180 s and was carried out in triplicate. A different plant was taken on each occasion and the PA signal was measured from the leaf located in the penultimate position

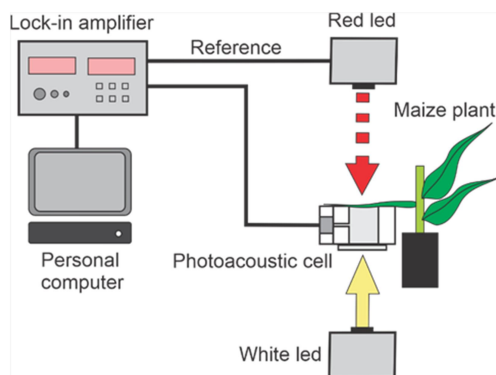

**Figure 1.** Schema of configuration used for measurement of oxygen evolution rate and thermal diffusivity.

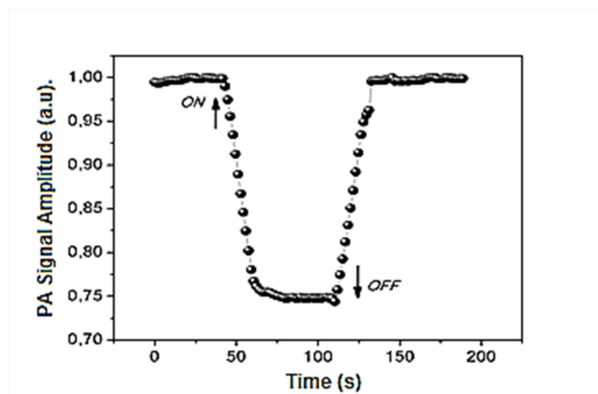

**Figure 2.** Typical curve to estimate the oxygen evolution rate. ON: White light is turned on and OFF: White light is turned off.

along the stem, which has the largest photosynthetic surface exposed directly to light, due to its location (Cayón-Salinas, 2001; Gong *et al.*, 2011). This choice is necessary to establish a comparative analysis biased to the leaf position. After each measurement, the plants were placed back into the greenhouse.

### Measurements of Oxygen Evolution Rate

A diagram of the experiment to monitor photosynthesis is shown in Figure 1. The measured area of the flag leaf was always kept in a region close to the leaf apex. The red-light beam from the LED (luminous power between 100 and 200 lm) was electronically modulated at 17 Hz, which is the resonant frequency of the closed PA cell (Popa and Petrus, 2017). This light beam affects the leaf surface, which is previously placed sealing the chamber of the PA cell. Thus, the distance between leaf and LED was approximately 2.5 mm.

The opposite side of the leaf was illuminated from a distance of 22.8 mm by a continuous white LED (1W- luminous flux: 100-200 lm) to saturate the photosynthetic process. Using the amplitude of the PA signal, detected as a function of the time, it is possible to study the photosynthesis activity in the plants, related to the periodic

oxygen release from the leaf. In a typical measurement of the rate of photosynthesis with this system, when the continuous white light is turned on (↑), the reaction centers of the leaf are saturated and the photobaric contribution does not appear; therefore, the PA signal is composed only of the photothermal contribution. When the white light is turned off (↓), the photobaric contribution reappears and the values return to their original state as shown in Figure 2. Thus, the percentage of oxygen release produced by the plant can be estimated (Malkin and Puchenkov, 1997).

### Thermal Diffusivity Measurements

After light absorption by pigments and energy-transfer processes, three major processes can happen in a leaf, namely, fluorescence, heating, and photochemistry, the last one being responsible for the oxygen emission. Therefore, to analyze photosynthesis, it is important to consider the OER, but also thermal parameters such as Thermal Diffusivity ( $D_{TH}$ ). The OER is affected by non-photosynthetic factors, linked to the diffusion of oxygen through the leaf tissues. However, the  $D_{TH}$ , associated to the rate of heat propagation in the leaf (Poulet *et al.*, 1983), This thermophysical parameter is related to the structural



characteristics, chemical composition and especially with water content in the sample.

The  $D_{TH}$  was estimated using the same measurement method that was employed to calculate the OER, but scanning the PA signal as a function of the modulation frequency ( $f$ ), of the incident periodic light-pulses on the maize leaves, always keeping the continuous white light on to inhibit the photosynthetic process. Thus, a curve of the photothermal contribution was obtained in the 17-100 Hz frequency range (Barja *et al.*, 2001).

For each treatment with different NPK fertilizer concentration, the  $D_{TH}$  of the maize leaves was calculated through the model proposed by Bedoya *et al.* (2015), considering Equation (1) and the cutting frequency ( $f_c$ ).

$$A' = \sqrt{f} \frac{\left( g e^{-\sqrt{\frac{f}{f_c}}} \right)^2 + (hC^{1/2})^2 + 2ghC^{1/2} e^{-\sqrt{\frac{f}{f_c}}} \cos\left(-\pi - \sqrt{\frac{f}{f_c}} - \varphi\right)}{\left( 1 + m^2 \sqrt{f}^6 + 2m\sqrt{f}^3 \cos\left(\frac{-7\pi}{4}\right) \right)} \quad (1)$$

Where,  $A'$  is the photothermal component;  $g$ ,  $h$  and  $m$  are constants;  $C = \left(1 - \frac{1}{x}\right)^2 + \left(\frac{1}{x}\right)^2$

$$\varphi = \arctan\left(\frac{1}{x-1}\right), \text{ and } = \sqrt{\frac{f}{f_c}} \text{ and } x = \dots$$

Also, the diffusion of oxygen can be obtained using the percentage values of fall or rise in the PA signal when the photosynthesis is saturated (Gordillo-Delgado *et al.*, 2016).

### Photosynthetic Pigment Measurements

In Figure 3 is described the experimental configuration of PA UV-Vis spectroscopy, which was used to determine the pigments content in the maize leaves. In this instrumentation, white light from a xenon lamp (Oriel, 1000W) passes through a modulator mechanism (chopper), whose frequency (17 Hz, resonant frequency of the

closed PA cell) is the reference for the lock-in amplifier (SR830). Then, the emerging modulated light is passed through a monochromator (Instruments SA, model TRIAX-190) configured to scan from 300 to

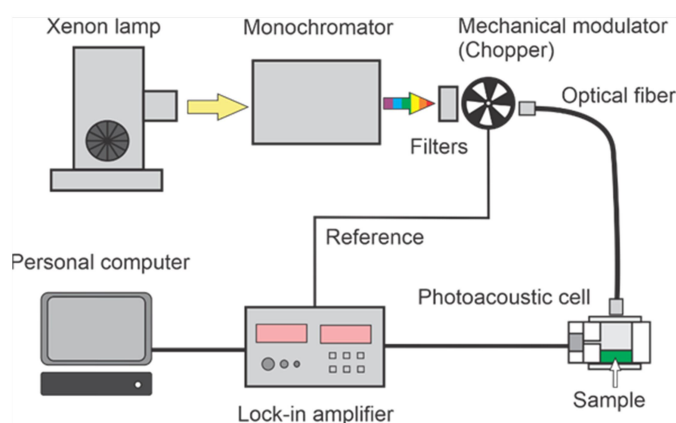

**Figure 3.** Schema of the configuration used for photoacoustic spectroscopy in the visible light range.



800 nm, with a 5 nm step. This modulated monochromatic light was guided through an optical fiber to impinge the macerated maize leaf deposited into the PA cell sample holder.

The measurements were taken immediately after preparation of the sample with the same procedure for avoiding spectra alteration induced by dynamic changes in the light absorption on the macerated leaves, which could cause chlorophyll oxidation and dehydration.

The PA spectrum is directly proportional to the absorption coefficient of the sample, so, the interference and light scattering are eliminated with this technique, which represents an important advantage over spectrophotometric methods. To discount spectral characteristics of the light source, the measured PA signal must be normalized with the signal from a black body absorber, in this case a sample of carbon black was used (Rosencwaig, 1978).

### Stomata Analysis

The stomatal analysis was conducted under randomized blocks experimental design, with four treatments and five replications, in which each concentration of NPK fertilizer was considered as a treatment for groups of 10 plants. The leaves were collected at the end of the experiment. After 40 days of monitoring photosynthetic parameters, three leaves from the upper part of each treated plant were cut and dyed with methylene blue, with a total of thirty leaves per treatment.

**Table 2.** Range of Oxygen Evolution Rate (OER) values for each treatment with NPK fertilizer concentration, considering only the data 10 days after fertilizer supplementation.

Dose concentration (g mL <sup>-1</sup> )	Minimum OER (%)	Maximum OER (%)	Interval (OER <sub>max</sub> -OER <sub>min</sub> )
0.256	12.5±0.1	23.4±0.8	10.9±0.9
0.382	7.7±0.4	17.6±0.2	9.9±0.6
0.510	10.7±0.04	23.3±0.05	12.6±0.09
0.688	6.3±0.03	14.3±0.3	8.0±0.3

The mean values of Stomatal Density (SD) and Stomatal Index (SI) were determined in the epidermal sections through 40x magnification. The samples were obtained by freehand cross-sections and analyzed with an optical microscope (Olympus CX41RF). Three repetitions for each treatment were carried out, corresponding to a total of 120 observations. The SD depends on the number of stomata and size of epidermal cells; considering that the expansion of these cells is related to the leaf location, light, and temperature, while the SI is defined as a function of Epidermal Cell Density (ECD) as follows:

$$SI = \frac{SD}{SD+ECD} 100\% \quad (2)$$

The SD was obtained by counting the number of stomata in an area of 4,347 mm<sup>2</sup>, equivalent to the diameter of the observed field, with an increase of 40X. Analysis of Variance (one-way ANOVA and ANOVA on Ranks) was applied to the SD and SI values to detect possible significant differences due to the treatments, using the Tukey test (P < 0.05).

### RESULTS AND DISCUSSION

Using the PA technique, effect of the NPK fertilizer on the photosynthetic activity of maize *Zea mays* L. (Poaceae) was evaluated, monitoring the OER of these treated plants. The *in situ* detection of PA signal during the *in vivo* leaf measurement with this non-destructive method is a functional advantage.

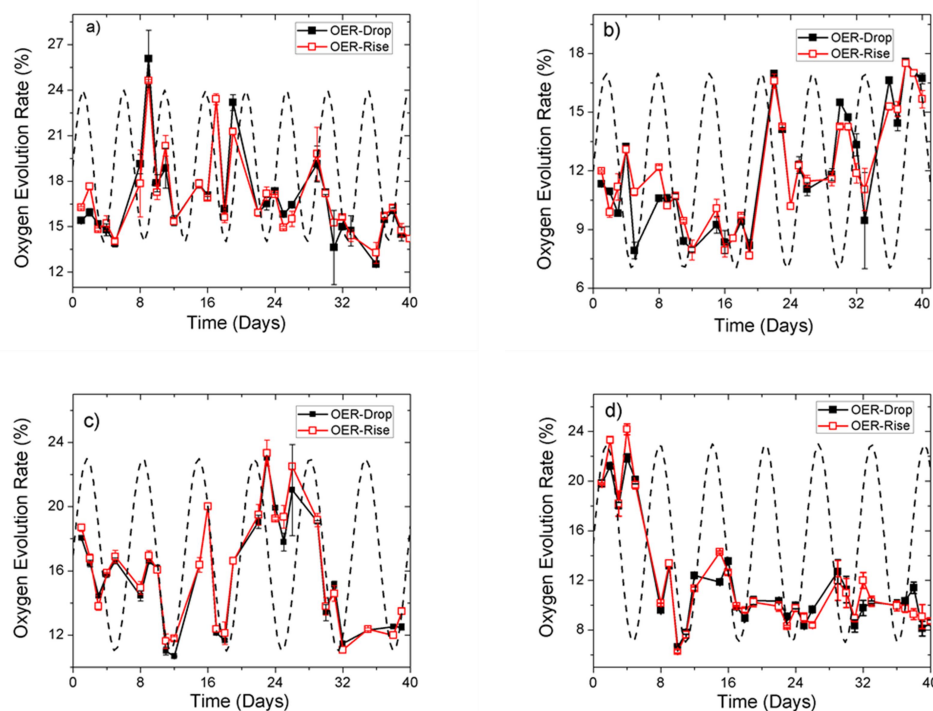

**Figure 4.** Plots of oxygen evolution rate vs. time of the treated plants with NPK fertilizer concentration of (a) 0.256, (b) 0.382, (c) 0.510, and (d) 0.688 g mL<sup>-1</sup>. The dotted lines correspond to a sine function, superimposed to estimate some parameters of the pattern.

### Oxygen Evolution Rate

The OER values corresponding to the plants treated with four different concentrations of NPK fertilizer showed different oscillatory patterns during the monitoring. The OER was calculated from the falling or rising of the PA signal caused by the photosynthesis saturation, both values (OER-drop and OER-rise) are plotted in Figure 4. These curves correspond to the average of measurements carried out throughout the experiment. The OER values ranged as shown in Table 2.

It is important to note that the OER pattern in each case presented different shapes from each other. The sinusoidal function (dotted line) was inserted in the plots of Figure 4 only as a guide for analysis. As shown in

Figure 4, it is possible to explain that the plants treated with the concentration of 0.256 g mL<sup>-1</sup>, after an adaptation period of 10 days after the fertilization treatment, had approximately 5.5% of OER oscillation “amplitude” (half of interval) and a “frequency” (rate of change of OER) around 1.3 cycles per day; while with other concentrations, i.e. 0.382, 0.51 and 0.688 g mL<sup>-1</sup>, this parameter had an approximate value of 5, 6, or 4% and a frequency of 1, 0.95, and 1 cycle per day, respectively.

As can be noticed in Figure 4 (d), the amplitude of the OER corresponding to the treatment with the highest concentration drastically decreases over time; perhaps because the excessive absorption of nutrients could be affecting the reaction centers and disturbing the normal functioning of oxygen release. Nakaji *et al.* (2001) reported a similar phenomenon in which the



photosynthesis of *Pinus densiflora* was reduced under different concentrations of nitrogen in the soil.

This altered pattern of the OER is an issue still to be discussed. Several hypotheses have been proposed about the origin of these photosynthetic behaviors (Roussel *et al.*, 2007; Roussel *et al.*, 2011). Some arguments describe the competition between the CO<sub>2</sub> and O<sub>2</sub> substrates as a delay in the release of CO<sub>2</sub> (photorespiration) after the oxygenation of Ribulose-1.5-Bisphosphate (RuBP), which provides elements that could lead to oscillations. It is also debated that this pattern of photosynthesis happens due to metabolic processes, such as carboxylation and oxygenation by the RuBP enzyme; however, this conduct can occur when the leaves are subject to sudden changes in environmental conditions (Walker, 1992). In this work, the experiment was carried out in equal controlled conditions; thus, the different behavior of OER curves (OER vs. time) favors the last explanation related to the plant metabolism.

### Thermal Diffusivity (D<sub>TH</sub>)

The D<sub>TH</sub> values of the leaves of maize plants, treated with different concentrations of the NPK fertilizer, were estimated from the data analysis of the PA signal amplitude as a function of modulation frequency of the incident light, under cancellation of the “photobaric” contribution. The averages of these D<sub>TH</sub> are registered in Table 3. Other researchers have reported results similar to

those observed in this study (Walker, 1992).

The lowest D<sub>TH</sub> values of the leaves (around  $3.6 \times 10^{-3} \text{ cm}^2 \text{ s}^{-1}$ ) were those obtained from the treatments with dose concentrations of 0.382 and 0.51 g mL<sup>-1</sup>. This could be associated with the possibility that these plants had the highest water losses by transpiration among all the treatments, because this thermal parameter is proportional to the water content in the sample.

### Photosynthetic Pigments

The presence of chlorophyll *a* and *b* in the leaves was detected by PA spectroscopy in the visible light range of the wavelengths between 430 and 670 nm. The PA signal amplitude was normalized in relation to the PA signal of the carbon black to eliminate incident light intensity variation associated with the spectral characteristics of the light source. The absorption centers related to the content and distribution of chlorophyll *a* and *b* were found. The spectral curves obtained from the plants treated with different concentration had a particular behavior; with application of 0.688 g mL<sup>-1</sup>, the intensity of the signal was the lowest, as can be seen in Figure 5. The treatment with the highest concentration could have affected the normal operation of chloroplasts and other organelles (Bondada and Syvertsen, 2003).

Although the PA signal has a phase component, it was not considered in this work because it was very sensible to noise. On the other hand, the normalized amplitude

**Table 3.** Values of Thermal Diffusivity (D<sub>TH</sub>) for maize leaves treated with the NPK fertilizer.

Dose concentration (g mL <sup>-1</sup> )	D <sub>TH</sub> <sup>a</sup> (×10 <sup>-3</sup> cm <sup>2</sup> s <sup>-1</sup> )
0.256	4.8±0.8 <i>ac</i>
0.382	3.6±0.5 <i>b</i>
0.510	3.6±0.3 <i>b</i>
0.688	3.9±0.2 <i>bc</i>

<sup>a</sup> Mean values±SE in the same column followed by a different letter are significantly different according to the Tukey test at P< 0.05, n= 10.



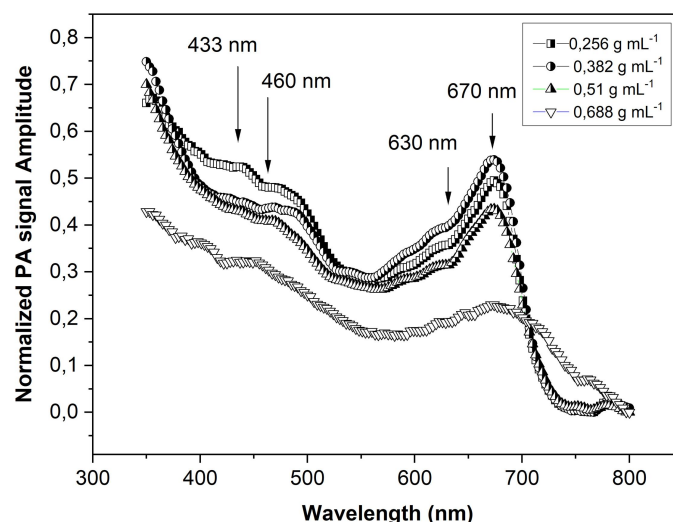

**Figure 5.** Representative spectra of maize leaves treated with different concentration of the NPK fertilizer. The lines with squares correspond to the dosage of  $0.256 \text{ g mL}^{-1}$ , circles to the dosage  $0.382 \text{ g mL}^{-1}$ , triangles (up) to  $0.51 \text{ g mL}^{-1}$ , and triangles (down) to  $0.688 \text{ g mL}^{-1}$ .

of the PA signal allows the easiest comparison with spectrophotometric absorption spectra reported by other authors (Veljovic-Jovanovic *et al.*, 2016).

The increased intensity of the PA spectral band related to chlorophyll *a*, corresponding to the dose of  $0.382 \text{ g mL}^{-1}$  concentration of applied fertilizer, and could be associated to the most efficient assimilation of N in this experiment. A similar behavior of the respective spectral shape was found for the  $0.232$  and  $0.51 \text{ g mL}^{-1}$  doses. However, for the highest  $0.688 \text{ g mL}^{-1}$  dose, the corresponding spectrum was characterized by the lowest intensity and a wide band associated to chlorophyll *a*, which was remarkably different. This is probably due to substrate acidification by excessive fertilizer, particularly Nitrogen (N).

It is interesting to note that 10 days after the fertilization treatment, the OER pattern had a change in which the lowest “amplitude” (half of the OER change interval) corresponded to the highest concentration dose of NPK fertilizer ( $0.688 \text{ g mL}^{-1}$ ), which can be related to the

chlorophyll content loss caused by over-fertilization.

Several studies about the fertilizer-chlorophyll correlation have been conducted. For instance, Ghosh *et al.* (2004) mention that the total chlorophyll content was higher in soybean plants treated organically than with 100% NPK fertilizers, despite the fact that the release of nitrate from organic manure was comparatively slow. On the other hand, Bojović and Marcović (2009) indicated that the most favorable fertilization variant for wheat cultivar was the NPK with the highest nitrogen content; this was related to the chlorophyll content in the leaves. Likewise, Latsague *et al.* (2014) reported that chlorophyll was the best indicator of the stimulatory effect of fertilization with N, P, and K on certain biochemical parameters of *Berberidopsis corallina*. Finally, Prihastanti *et al.* (2019) reported that in maize plants grown in nano-silica-compost fertilizer, the total amount of chlorophyll tends to decrease, but the chlorophyll content increases in nano-silica-NPK fertilizer.



**Table 4.** Mean values of Stomatal Index (SI) and Stomatal Density (SD) recorded for maize leaves of plants treated with different doses of NPK fertilizer (n= 10).<sup>a</sup>

Dose Concentration (g mL <sup>-1</sup> )	SI (%)	SD (μm <sup>-2</sup> )
0.256	18±1 <i>bc</i>	8±1 <i>b</i>
0.382	19±1 <i>ac</i>	10±1 <i>a</i>
0.510	20±1 <i>a</i>	11±1 <i>a</i>
0.688	18±1 <i>b</i>	8±2 <i>b</i>

### Stomatal Index and Stomatal Density

The obtained values of morphoanatomic parameters SD and SI are shown in Table 4. The SI data, 20±1 and 19±1%, corresponding to the plants treated with 0.510 and 0.382 g mL<sup>-1</sup> fertilizer concentrations, were the highest values compared to the other concentrations. The slight variation of the SD and SI of the leaves can be evidence of influence of the fertilizer on the anatomy and morphology of the plants. This is in agreement with Gul *et al.* (2015) report, which suggests that growth and yield traits are affected by N, P, and K supplied concentrations. Likewise, Efthimiadou *et al.* (2010) indicated that combined organic and inorganic fertilizers, which have similar N content, resulted in further increase in photosynthetic rate, in the stomatic conductance and increased yield in maize plants. Also, Hussain *et al.* (2015) reported that increasing potassium (K<sup>+</sup>) application rate in maize plants improves the physiological characteristics (shoot length, root length, fresh root weight, fresh shoot weight and dry root weight) and nutrient absorption. The influence of the NPK concentrations on plant morpho-anatomy could be linked to the photosynthetic activity and results are presented in the Table 4.

The oxygen produced by photosynthesis can pass through the stomata and leaf cuticle, which are synthesized in the epidermal cells. According to the microscopic analysis and OER monitoring, the leaves of maize treated with medium concentrations of fertilizer (0.382 and 0.51 g

mL<sup>-1</sup>) induced the highest values of SI and SD. The balance of photosynthesis and water loss during plant development is achieved through SD and stomatal aperture regulation. The SD and SI are related to stomatal development, and both are influenced by environmental conditions of growth.

It is important to note that this work did not include a study of the correlation between the measured parameters of photosynthetic activity (OER, SI, SD and pigment content), because the interest was focused on the effect of the concentration of a conventional chemical fertilizer on these variables.

### CONCLUSIONS

The intensity of the PA spectral band related to chlorophyll *a* changed according to the concentration of NPK fertilizer applied to maize plants. For the highest concentration of applied fertilizer (0.688g mL<sup>-1</sup>), the spectrum was remarkably different, characterized by the lowest intensity and width of this band; the corresponding OER pattern had the lowest “amplitude” (half of OER change interval). According to the microscopic analysis and OER monitoring, the leaves of maize treated with doses of the medium concentrations (0.382 g mL<sup>-1</sup> and 0.51 g mL<sup>-1</sup>) presented the highest values of SI and SD, and the lowest D<sub>TH</sub> (around 3.6×10<sup>-3</sup> cm<sup>2</sup> s<sup>-1</sup>). These data are evidence of the potential of the PA technique to evaluate the effect of a fertilizer on the photosynthetic activity of maize plants and to establish the optimal fertilizer application rate. The use of NPK fertilizer

dose of  $0.382 \text{ g mL}^{-1}$ , which is 25% lower than the dose used as standard ( $0.51 \text{ g mL}^{-1}$ ), suggests a reduction of the amount of applied fertilizer without serious alteration of physiological parameters SI, SD and  $D_{\text{TH}}$ . This could be useful for decreasing the environmental impact and production cost of maize crop.

### ACKNOWLEDGEMENTS

The authors thank the University of Quindío and MINCIENCIAS for their financial support through the project number 916. This work was partially funded by the OMICAS program: Optimización Multiescala In-silico de Cultivos Agrícolas Sostenibles (Infraestructura y validación en Arroz y Caña de Azúcar), anchored at the Pontificia Universidad Javeriana in Cali and funded within the Colombian Scientific Ecosystem by The World Bank, the Colombian Ministry of Science, Technology and Innovation, the Colombian Ministry of Education, the Colombian Ministry of Industry and Tourism, and ICETEX, under grant FP44842-217-2018 and OMICAS Award ID: 792-61187. A. Bedoya gratefully acknowledges the support from the *Programa de becas posdoctorales 2020-2021* at UNAM-DGAPA and D.H Zapata gratefully acknowledges the support from *Programa de becas nacionales CONACYT 2021*.

### REFERENCES

1. Acosta-Avalos D., Alvarado-Gil J. J., Vargas H., Frías-Hernández J., Olalde-Portugal V. and Miranda L. C. M. 1996. Photoacoustic Monitoring of the Influence of Arbuscular Mycorrhizal Infection on the Photosynthesis of Corn (*Zea mays* L.). *Plant Sci.*, **119**: 183-190.
2. Barja, P. R., Manzanares, A. M., Da Silva, E. C., Magalhães, A. C. and Alves, P. L. 2001. Photosynthesis in Eucalyptus Studied by the Open Photoacoustic Technique: Effects of Irradiance and Temperature. *Acoust. Phys.*, **47**: 16-21.
3. Bedoya, A., Marín, E., Manzanares, A. M., Zambrano-Arjona, M. and Riech, I. 2015. On the Thermal Characterization of Solids by Photoacoustic Calorimetry: Thermal Diffusivity and Linear Thermal Expansion Coefficient. *Thermochim. Acta*, **614**: 52-58.
4. Bilger, W. and Bjorkman, O. 1990. Role of the Xanthophyll Cycle in Photoprotection Elucidated by Measurements of Light-Induced Absorbance Changes, Fluorescence and Photosynthesis in Leaves of *Hedera canariensis*. *Photosynth. Res.*, **25**: 173-185.
5. Bojović, B. and Marković, A. 2009. Correlation between Nitrogen and Chlorophyll Content in Wheat (*Triticum aestivum* L.). *Kragujevac J. Sci.*, **31**: 69-74.
6. Bondada, B. R. and Syvertsen, J. P. 2003. Leaf Chlorophyll, Net Gas Exchange and Chloroplast Ultrastructure in Citrus Leaves of Different Nitrogen Status. *Tree Physiol.*, **23**: 553-559.
7. Bushong, J. T., Mullock, J. L., Arnall, D. B. and Raun, W. R. 2018. Effect of Nitrogen Fertilizer Source on Corn (*Zea mays* L.) Optical Sensor Response Index Values in a Rain-Fed Environment. *J. Plant Nutr.*, **41(9)**: 1172-1183.
8. Canaani, O., Ronen, R., Garty, J., Cahen, D., Malkin, S. and Galun, M. 1984. Photoacoustic Study of the Green Alga *Trebouxia* in the Lichen *Ramalina duriaei* in Vivo. *Photosynth. Res.*, **5**: 297-306.
9. Cayón-Salinas, D. G. 2001. Evolución de la Fotosíntesis, Transpiración y Clorofila Durante el Desarrollo de la Hoja de Plátano (*Musa AAB Simmonds*). *Infomusa (FRA)*, **12(15)**: 10.
10. Chapin F. S. 1980. The Mineral Nutrition of Wild Plants. *Ann. Rev. Ecol. Syst.*, **11**: 233-60.
11. Efthimiadou, A., Bilalis, D., Karkanis, A. and Froud-Williams, B. 2010. Combined Organic/Inorganic Fertilization Enhance Soil Quality and Increased Yield, Photosynthesis and Sustainability of Sweet Maize Crop. *Aust. J. Crop Sci.*, **4**: 722-729.
12. Fan, X., Cao, X., Zhou, H., Hao, L., Dong, W., He, C., Xu, M., Wu, H., Wang, L., Chang, Zh. and Zheng, Y. 2020. Carbon Dioxide Fertilization Effect on Plant Growth under Soil Water Stress Associates with Changes in Stomatal Traits, Leaf



- Photosynthesis, and Foliar Nitrogen of Bell Pepper (*Capsicum annuum* L.). *Environ. Exp. Bot.*, **179**: 1-13.
13. Ghosh, P. K., Ajay, Bandyopadhyay, K. K. Manna, M. C. Mandal K. G., Misra, A. K. and Hati, K. M. 2004. Comparative Effectiveness of Cattle Manure, Poultry Manure, Phosphocompost and Fertilizer-NPK on Three Cropping Systems in Vertisols of Semi-Arid Tropics. II. Dry Matter Yield, Nodulation, Chlorophyll Content and Enzyme Activity. *Bioresour. Technol.*, **95**: 85-93.
  14. Gong, X., Hong, M., Wang, Y. Wang, Y., Zhou, M., Cai, J., Liu, C., Gong, S. and Hong, F. 2011. Cerium Relieves the Inhibition of Photosynthesis of Maize Caused by Manganese Deficiency. *Biol. Trace. Elem. Res.*, **141**: 305-316.
  15. Gordillo-Delgado, F. and Botero-Zuluaga, M. 2020. Monitoreo Fotoacústico de Plantas *Musa acuminata* (Musaceae) Infectadas con el Hongo *Fusarium oxysporum* (Nectriaceae). *Rev. Acad. Colomb. Cien. Ex. Fis. Nat.*, **44(173)**: 1073-1082.
  16. Gordillo-Delgado, F., Marín, E. and Calderón, A. 2016. Effect of *Azospirillum brasilense* and *Burkholderia unamae* Bacteria on Maize Photosynthetic Activity Evaluated Using Photoacoustic Technique". *Int. J. Thermophys.*, **37**: 1-11.
  17. Gordillo-Delgado, F., Zuluaga-Acosta, J. and Restrepo-Guerrero, G. 2020. Effect of the Suspension of Ag-Incorporated TiO<sub>2</sub> Nanoparticles (Ag-TiO<sub>2</sub> NPs) on Certain Growth, Physiology and Phytotoxicity Parameters in Spinach Seedlings. *PLoS One*, **15(12)**: e0244511.
  18. Gul, S., Khan, M. H., Khanday, B. A. and Nabi, S. 2015. Effect of Sowing Methods and NPK Levels on Growth and Yield of Rainfed Maize (*Zea mays* L.). *Scientifica*, Volume 2015, Article ID 198575, PP. 1-6.
  19. Herbert, S. K., Biel, K. Y. and Vogelmann, T. C. 2006. A Photoacoustic Method for Rapid Assessment of Temperature Effects on Photosynthesis. *Photosynth. Res.*, **87(3)**: 287-294.
  20. Hussain, A., Arshad, M.G., Ahmad, Z., Ahmad, H. T., Afzal, M. and Ahmad, M. 2015. Potassium Fertilization Influences Growth, Physiology and Nutrients Uptake of Maize (*Zea mays* L.). *Cercetari Agronomice in Moldova (Agronomic Research in Moldavia)*, **1**: 37-50.
  21. Latsague, M., Saez, P. and Mora, M. 2014. Efecto de la Fertilización con Nitrógeno, Fósforo y Potasio, Sobre el Contenido Foliar de Carbohidratos, Proteínas y Pigmentos Fotosintéticos en Plantas de *Berberidopsis corallina* Hook. f. *Gayana Bot.*, **71(1)**: 37-42.
  22. Liu, C. W., Sung, Y., Chen, B. C. and Lai, H. Y. 2014. Effects of Nitrogen Fertilizers on the Growth and Nitrate Content of Lettuce (*Lactuca sativa* L.). *Int. J. Environ. Res. Public Health*, **11**: 4427-4440.
  23. Malkin, S. and Puchenkov, O. V. 1997. The Photoacoustic Effect in Photosynthesis. Chap. 2. In: "Progress in Photothermal and Photoacoustic Science and Technology", (Eds.): Mandelis, A. and Hess, P. Vol. 3, SPIE, Bellingham, WA.
  24. Malkin, S., Herber, S. K. and Fork, D. C. 1990. Light Distribution, Transfer and Utilization in the Marine Red Alga (*Porphyra perforate*) from Photoacoustic Energy-Storage Measurements. *Biochim. Biophys. Acta*, **1016**: 177-189.
  25. Mandelis, A. and Hess, P. 1997. The Photoacoustic Effect in Photosynthesis. In: "Life and Earth Sciences". 3rd Edition. SPIE Publisher, Washington, US, PP. 17-54.
  26. Marín, E. 2008. Escuchando la Luz: Breve Historia y Aplicaciones del Efecto Fotoacústico. *J. Phys. Educ.*, **2**: 209-215.
  27. Marques, D. J., Bianchini, H. C., Maciel, G. M., Nunes de Mendoza T. F. and Silva M. F. 2021. Morphophysiological Changes Resulting from the Application of Silicon in Corn Plants under Water Stress. *J. Plant Growth Regul.*, **41(2)**: 569-584
  28. Mesquita, R. C., Mansanares, A. M., da Silva, E. C., Barja, P. R., L., Miranda, C. M. and Vargas, H. 2006. Open Photoacoustic Cell: Applications in Plant Photosynthesis Studies. *Instr. Sci. Tech.*, **34(1-2)**: 33-5.
  29. Miskoska-Milevska, E., Najdenovska, O., Popovski, Z. T. and Dimovska, D. 2018. The Influence of the Microbiological Fertilizer-Slavol on Cauliflower Growth. *Rom. Biotechnol. Lett.*, **23**: 13511-13516.
  30. Moreno-Berocal, A. M., Narro-León, I. A., Vanegas-Angarita, H., Molina-Gómez, C. E. and Ospina-Rojas, J. G. 2008. *Fertilización del Maíz en la Zona Cafetera*



- Colombiana. ISSN-0120-0178, Gerencia Técnica/Programa de Investigación Científica, Avances Técnicos, Chinchiná, Caldas, Colombia, PP. 1-4.
31. Nakaji, T., Fukami, M., Dokiya, Y. and Izuta, T. 2001. Effects of High Nitrogen Load on Growth, Photosynthesis and Nutrient Status of *Cryptomeria japonica* and *Pinus densiflora* Seedlings. *Trees*, **15**: 453-461.
  32. Nargis J. and Nilufar Y. 2017. Growth Responses, Pigment and Stomatal Behaviour of Maize to Foliar Application of NAA. *J. Bangladesh Acad. Sci.*, **41**: 1-9.
  33. Popa, C. and Petrus, M. 2017. Heavy Metals Impact at Plants Using Photoacoustic Spectroscopy Technology with Tunable CO<sub>2</sub> Laser in the Quantification of Gaseous Molecules. *Microchem.*, **134**: 390-399.
  34. Poulet P., Cahen D. and Malkin S., 1983. Photoacoustic Detection of Photosynthetic Oxygen Evolution from Leaves: Quantitative Analysis by Phase and Amplitude Measurements, *Biochim. Biophys. Acta*, **724**: 433-446.
  35. Prihastanti, E., Subagio, A. and Ngadiwiyana. 2019. The Comparison of Chlorophyll a, b, and the Total of Maize (*Zea mays saccharata sturt l*) var p-21 by Applying Fertilizers of Nanosilica-NPK and Nanosilica-Manure. *J. Phys. Conf. Ser.*, **1217**: 1-8.
  36. Rao, N. K., Hanson, J., Dulloo, M. E., Ghosh, K., Novell, D. and Larinde, M. 2007. Manual Para el Manejo de Semillas en Bancos de Germoplasma. In: "Manuales para Bancos de Germoplasmas". 8th Edition. Bioversity International Publisher: Roma, Italia, PP. 56-91.
  37. Rop, K., Karuku, G. N., Mbui, D., Michira, I. and Njomo, N. 2018. Formulation of Slow Release NPK Fertilizer (Cellulose-Graft-Poly(Acrylamide)/Nano-Hydroxyapatite/Soluble Fertilizer) Composite and Evaluating Its N Mineralization Potential. *Ann. Agric. Sci.*, **63(2)**: 163-172.
  38. Rosencwaig, A. 1978. Theoretical Aspects of Photoacoustic Spectroscopy, *J. Appl. Phys.*, **49**: 2905-2910.
  39. Rosencwaig, A. and Gersho, A. 1976. Theory of the Photoacoustic Effect with Solids. *J. Appl. Phys.*, **47**: 64-69.
  40. Roussel, M. R., Ivlev, A. A. and Igamberdiev, A. U. 2007. Oscillations of the Internal CO<sub>2</sub> Concentration in Tobacco Leaves Transferred to Low CO<sub>2</sub>. *J. Plant. Physiol.*, **164**: 1188-1196.
  41. Roussel, M. R., Ivlev, A. A. and Igamberdiev, A. U. 2011. Dynamics and Mechanisms of Oscillatory Photosynthesis. *BioSystems.*, **103**: 230-238.
  42. Sarwar, N., Saifullah, M. S., Zia, M. H., Naeem, N., Bibia, S. and Farida, G. 2010. Role of Mineral Nutrition in Minimizing Cadmium Accumulation by Plants. *J. Sci. Food Agric.*, **90**: 925-937.
  43. Veljovic-Jovanovic, S., Vidovic, M., Morina, F., Prokic, Lj. and Todorovic, D. M. 2016. Comparison of Photoacoustic Signals in Photosynthetic and Nonphotosynthetic Leaf Tissues of Variegated *Pelargonium zonale*. *Int. J. Thermophys.*, **37(91)**: 2-11.
  44. Walker, D. A. 1992. Concerning oscillations. *Photosynth. Res.*, **34**: 387-395.
  45. Yousef, A. F., Ali, M. M., Rizwan, H. M., Tadda, S. A., Kalaji, H. M., Yang, H., Ahmed, M., Wróbel, J., Xu, Y. and Chen, F. 2021. Photosynthetic apparatus performance of tomato seedlings grown under various combinations of LED illumination. *PLoS One*, **16(4)**: 1-17.



## به کارگیری روش فوتوآکوستیک برای ارزیابی مقدار کود NPK در ذرت (*Zea mays L.*)

ف. گوردیلو-دلگادو، د. ه. زاپاتا-سارمیتو، و ا. بدویا

### چکیده

در این پژوهش، فعالیت فتوستنتزی تعدادی گیاه ذرت (*Zea mays L.*) که در غلظت‌های مختلف کود شیمیایی NPK رشد کرده بودند، ارزیابی و مقایسه شد تا معیاری مؤثر برای مصرف مشخص شود. گیاهان در شرایط گلخانه ای در محیط ضد عفونی شده کشت و رشد کردند تا از تامین کنترل شده مواد تغذیه ای اطمینان حاصل شود. تراکم روزنه (SD) و نمایه یا شاخص روزنه (SI) گیاهان از طریق تجزیه و تحلیل میکروگراف (micrograph analysis) برآورد شد. در حالی که سرعت پدید اکسیژن، منحنی های طیفی جذب، و انتشار حرارتی (thermal diffusivity) برگ های گیاه با استفاده از روش فوتوآکوستیک اندازه گیری شد. نتایج مربوط به فعالیت فتوستنتزی و انتشار حرارتی نشان دهنده یک الگوی رفتاری نوسانی در طول دوره رشد بود و ویژگی های این نوسانات تحت تأثیر کاربرد کود NPK قرار داشت. تجزیه و تحلیل طیف سنجی فوتو آکوستیک نشان داد که تیمار با بالاترین مقدار کود NPK منجر به کاهش جذب کلروفیل  $a$  و  $b$  می شود. بر اساس نتایج، روش پیشنهادی و تکنیک مورد استفاده می تواند در پایش متغیرهای قابل اندازه گیری برای ارزیابی تأثیر کود روی گیاهانی مانند ذرت کاربرد داشته باشد که این امر امکان تعیین مقدار مناسب (کود) را فراهم می کند.