

A Comparative Study Between Artificial Neural Networks and Adaptive Neuro-Fuzzy Inference Systems for Modeling Energy Consumption in Greenhouse Tomato Production: A Case Study in Isfahan Province

B. Khoshnevisan^{1*}, S. Rafiee¹, J. Iqbal², Sh. Shamshirband³, M. Omid¹, N. Badrul Anuar⁴, and A. W. Abdul Wahab⁴

ABSTRACT

In this study greenhouse tomato production was investigated from energy consumption and greenhouse gas (GHG) emission point of views. Moreover, artificial neural networks (ANNs) and adaptive neuro-fuzzy inference systems (ANFIS) were employed to model energy consumption for greenhouse tomato production. Total energy input and output were calculated as 1,316.14 and 281.1 GJ ha⁻¹. Among the all energy inputs, natural gas and electricity had the most significant contribution to the total energy input. Evaluations of GHG emission illustrated that the total GHG emission was estimated at 34,758.11 kg CO₂eq ha⁻¹ and, among all the inputs, electricity played the most important role, followed by natural gas. Comparison between ANN and ANFIS models showed that, due to employing fuzzy rules, the ANFIS-based models could model output energy more accurately than ANN models. Accordingly, correlation coefficient (R), Root Mean Square Error (RMSE) and Mean Absolute Percentage Error (MAPE) for the best ANFIS architecture were calculated as 0.983, 0.025, and 0.149, respectively, while these performance parameters for the best ANN model were computed as 0.933, 0.05414, and 0.279, respectively.

Keywords: Neuro-fuzzy, Greenhouse crop production, GHG emission.

INTRODUCTION

Tomato (*Solanum lycopersicum*), which is originally from America, is now widely grown around the world, often in greenhouses in cooler areas. Iran is regarded as one of the major tomato producers in the world. In 2012, Iran ranked sixth among the most important tomato producers with total production of 6,000,000 million tons (FAO,

2012). A large share of tomatoes produced in Iran is grown in greenhouses. From 2002 to 2008, areas under greenhouse in Iran increased from 3,380 ha to 7,000 ha and the share of greenhouse production included: vegetables 59.3%, flowers 39.81%, fruits 0.54% and mushroom 0.35% (Pahlavan *et al.*, 2011).

Agricultural productivity increased significantly during 20th century, with

¹ Department of Agricultural Machinery Engineering, Faculty of Agricultural Engineering and Technology, University of Tehran, Karaj, Islamic Republic of Iran.

*Corresponding author; e-mail: b_khoshnevisan@ut.ac.ir

² Department of Software Engineering, Faculty of Computer Science and Information Technology, University of Malaya, 50603 Kuala Lumpur, Malaysia.

³ Department of Computer System and Technology, Faculty of Computer Science and Information Technology, University of Malaya, 50603 Kuala Lumpur, Malaysia.

⁴ Department of Computer System and Technology, Faculty of Computer Science and Information Technology, University of Malaya, 50603 Kuala Lumpur, Malaysia.



mechanization leading to a dramatic rise in labor productivity. Improved production techniques, intensive use of fertilizers, pesticides, and other energy inputs along with progress in animal husbandry helped to increase yields. However, excessive use of these energy inputs has resulted in a variety of problems such as global warming and air pollution which are the major concerns related to the use of fossil energy (Nemecek and Kagi, 2007). Energy consumption in agricultural production, especially in greenhouse production, is so intensive because large quantities of energies like diesel fuel, machinery, electricity, natural gas, etc. are used (Heidari and Omid, 2011). Effective energy use and sustainability in agricultural production are significantly correlated and literature is repeated with reports focused on energy consumption in agricultural production (Hatirli *et al.*, 2006; Tabatabaie *et al.*, 2013; Ozkan *et al.*, 2011; Pishgar-Komleh *et al.*, 2012; Mousavi-Avval *et al.*, 2011; Singh *et al.*, 2002; Omid *et al.*, 2011; Nassiri and Singh, 2010).

Energy modeling is an interesting subject for engineers and scientists who are concerned with energy production and consumption and related environmental impacts (Safa and Samarasinghe, 2011). For many years, regression analysis has been employed as a common modeling technique. The main disadvantage of regression analysis as a statistical method is that it requires some assumptions about the functional form (Pahlavan *et al.*, 2012). Recently, artificial neural networks (ANNs) and adaptive neuro-fuzzy inference systems (ANFIS) are two main artificial intelligences (AI) modeling techniques which are widely applied tools because they are more efficient and less time consuming in modeling complex systems compared to other mathematical models such as regression (Pahlavan *et al.*, 2012). The advantage of AI over statistical models is reported by many researchers (Lette *et al.*, 1994 ; Benediktsson *et al.*, 1990; Razi and Athappilly 2005). Kaul *et al.* (2005) employed ANN for predicting corn and

soybean yield. In another study conducted by Lim *et al.* (2007), ANN approach was used for prediction of ammonia emission from field-applied manure. Naderloo *et al.* (2012) used ANFIS models for predicting crop yield based on different energy inputs.

On the basis of the foregoing discussion, the main objectives of the present study were to: (a) calculate energy input and output in greenhouse tomato production; (b) determine GHG emission related to the tomato production, and (c) predict output energy on the basis of energy inputs using AI. Accordingly, several ANN and ANFIS models were developed and their prediction accuracy was evaluated using quality parameters.

MATERIALS AND METHODS

Data Collection and Methods

Isfahan province is one of the major greenhouse production regions in Iran. This province is located in central Iran within 30° 43' and 34° 27' north latitude and 49° 36' and 55° 31' east longitude. The rural areas of Fereydonshahr city was selected for sampling and data was collected in the period of 2011-2013. To determine the required sample size, random sampling method was employed using the following formula (Mousavi-Avval *et al.*, 2011):

$$n = \frac{N \times s^2 \times t^2}{(N - 1)d^2 + (s^2 \times t^2)} \quad (1)$$

Where, n presents the required sample size, N is the number of greenhouse tomato producers in the studied area, s is the standard deviation in the pre-tested data, t presents t value at 95% confidence limit (1.96) and d is the acceptable error which was defined to be 5 for 95% confidence (Mousavi-Avval *et al.*, 2011; Pahlavan *et al.*, 2012). Applying the mentioned formula, the sample size was determined to be 78 tomato producers who were randomly selected and interviewed using face-to-face interviews.

The main inputs used during production season included human labor, chemical fertilizers, farmyard manure (FYM), machinery, diesel fuel, electricity, biocides, natural gas, irrigation water and seeds. Tomatoes produced were chosen as the only output energy. All input materials have different measuring unit. To train artificial-based model, these inputs were converted to their energy equivalents using energy coefficients (Table 1). Then, input energies were selected as inputs of the models and the output energy was chosen as the only output of the model. To calculate Machinery energy, all greenhouse holders were asked about the types and weights of the applied machinery in different operations. Furthermore the machinery energy was computed using following formula (Kitani, 1999):

$$ME = \frac{ELG}{TC_a} \quad (2)$$

Where, 'ME' is the machine energy (MJ ha⁻¹), 'G' the weight of machine (kg), 'E' the production energy of machine (MJ kg⁻¹ yr⁻¹) that is shown in Table 1, 'L' the useful life of machine (year), 'T' the economic life of machinery (h) and 'C_a' the effective field capacity (ha h⁻¹) (Pishgar-Komleh *et al.*, 2012; Khoshnevisan *et al.*, 2015).

To investigate the different forms of energies that were used in greenhouse tomato production, the energy inputs were divided into direct and indirect or renewable and nonrenewable forms. Human labor, diesel fuel, electricity, natural gas, and irrigation water belonged to direct energy sources, while the sources of indirect energy consisted of FYM, chemical fertilizers, biocides and machinery. Also, renewable energy included human labor, FYM, and irrigation water and nonrenewable energy sources consisted of electricity, natural gas, machinery, diesel fuel, biocides, and

Table 1. Energy coefficients of different inputs and output.

Inputs	Unit	Energy coefficients (GJ unit ⁻¹)	Reference
A. Inputs			
1. Machinery			
Tractor and self-propelled	Kg yr ^a	9-10×10 ⁻³	(Kitani, 1999)
Stationary equipment	Kg yr ^a	8-10×10 ⁻³	(Kitani, 1999)
Implement and machinery	Kg yr ^a	6-8×10 ⁻³	(Kitani, 1999)
2. Human labor	h	1.96×10 ⁻³	(Pahlavan <i>et al.</i> , 2012)
3. Natural gas	m ³	49.5×10 ⁻³	(Kitani, 1999)
4. Diesel fuel	L	47.8×10 ⁻³	(Kitani, 1999)
5. Biocide			
Herbicide	kg	85×10 ⁻³	(Kitani, 1999)
Fungicide	kg	295×10 ⁻³	(Kitani, 1999)
Insecticide	kg	115×10 ⁻³	(Kitani, 1999)
6. Fertilizers			
Nitrogen (N)	kg	66.14×10 ⁻³	(Omid <i>et al.</i> , 2011)
Phosphate (P ₂ O ₅)	kg	12.44×10 ⁻³	(Omid <i>et al.</i> , 2011)
Potassium (K ₂ O)	kg	11.15×10 ⁻³	(Omid <i>et al.</i> , 2011)
7. Micro (M)	kg	120×10 ⁻³	(Pahlavan <i>et al.</i> , 2012)
8. FYM	kg	0.3×10 ⁻³	(Pahlavan <i>et al.</i> , 2012)
9. Water for irrigation	m ³	1.02×10 ⁻³	(Omid <i>et al.</i> , 2011)
10. Electricity	kWh	11.93×10 ⁻³	(Singh <i>et al.</i> , 2002)
11. Seeds	kg	10 ⁻³	(Hatirli <i>et al.</i> , 2006)
B. Out put			
1. Tomato	kg	0.8×10 ⁻³	(Hatirli <i>et al.</i> , 2006)

^a The economic life of machine (year).



chemical fertilizers (Rafiee *et al.*, 2010).

Production, storage, distribution of agricultural inputs and their applications with agricultural machinery lead to combustion of fossil fuel and use of energy from alternative sources, which emit CO₂ and other greenhouse gases (GHGs) into the atmosphere (Lal, 2004). In order to convert energy inputs into their carbon emission equivalent, carbon emission coefficients were used (Table 2). GHG emissions were computed by multiplying the amount of energy inputs by their corresponding carbon emission coefficients.

Development of ANN Models

ANNs are data-processing systems inspired by biological neural system and are used to solve a wide variety of problems in science and engineering, particularly for some areas where the conventional modeling methods fail (Najafi *et al.*, 2009). The principles of ANN are well documented in the literature, therefore, no more details will be presented here.

Several training algorithms can be employed in evaluating the network, of which back-propagation (BP) and Levenberg–Marquardt (LM) are the most important ones. Although BP algorithm is very popular, in comparison with LM training algorithm, it is often too slow for

practical problems because it needs small learning rates for stable learning (Ghobadian *et al.*, 2009). Back-propagation training algorithms gradient descent and gradient descent with momentum along with LM algorithm were practiced in order to find the best ANN model. Also, several hidden layers with distinct neurons in each one were evaluated to find the best network architecture. Matlab's M-file version 7.14.0.739 (R2012a), were used and different ANN programs were written to find the best ANN topology.

Adaptive Neuro-Fuzzy Inference System

ANFIS consists of if–else rules and input–output data couples of fuzzy and it uses neural network’s learning algorithms for training (Bektas Ekici and Aksoy, 2011; Petković *et al.*, 2014). ANFIS is a combination of ANN and fuzzy-logic model which gives the ability of modeling uncertain and imprecise data (Liu and Ling, 2003; Shamshirband *et al.*, 2010).

Propagation and hybrid, which are composed of back-propagation learning algorithm and least square method, are regarded as two learning methods generally used in ANFIS models to specify the relationship between input and output and to determine optimized distribution of MFs

Table 2. Greenhouse gas (GHG) emission coefficients of agricultural inputs.

Inputs	Unit	GHG coefficient ^a	Reference
Machinery	MJ	0.071	(Pishgar-Komleh <i>et al.</i> , 2012)
Diesel fuel	L	2.76	(Pishgar-Komleh <i>et al.</i> , 2012)
Chemical fertilizers			
Nitrogen (N)	kg	1.3	(Lal, 2004)
Phosphate (P ₂ O ₅)	kg	0.2	(Lal, 2004)
Potassium (K ₂ O)	kg	0.2	(Lal, 2004)
Biocide			
Herbicide	kg	6.3	(Lal, 2004)
Insecticide	kg	5.1	(Lal, 2004)
Fungicide	kg	3.9	(Lal, 2004)
Natural gas	m ³	0.85	(Lal, 2004)
Electricity ^b	kWh	0.608	(Pishgar-Komleh <i>et al.</i> , 2012)

^a kg CO₂eq unit⁻¹, ^b The power plant burns LNG.

(Naderloo *et al.*, 2012; Shamshirband *et al.*, 2014). Each ANFIS network contains five layers as shown in Figure 1. The basic structure of the type of fuzzy inference system is a model that maps input characteristics to input MFs, input MF to rules, rules to a set of output characteristics, output characteristics to output MFs, and the output MF to a single-valued output or a decision associated with the output.

The main limitation of developing ANFIS networks relates to the number of input variables because when the number of ANFIS inputs exceeds five, network fails due to the increased computational time and rule numbers (Naderloo *et al.*, 2012). In this study, the number of input variables was ten including labor, machinery, diesel fuel, chemical fertilizers, biocides, irrigation water, natural gas, electricity, FYM, and seeds. To find the best ANFIS architecture, two main topologies were developed and their results were compared.

In the first topology, as illustrated in Figure 2, ten energy inputs were divided into five groups and each group entered to one ANFIS network and, accordingly, the outputs of ANFIS 1 and 2 were selected as inputs for ANFIS 6 and predicted values by ANFIS 3 to 5 were chosen as inputs for ANFIS 7. Finally, predicted values 6 and 7 were entered into

ANFIS 8 and the output energy was forecasted.

In the second ANFIS topology, seven ANFIS networks were developed to predict output energy. Accordingly, ten inputs were clustered into four groups and each one was selected as input for ANFIS networks 1 to 4 (Figure 3). The output energy was forecasted by ANFIS 7 which was composed of predicted values 5 and 6.

In order to create FIS, MATLAB's M-file version 7.14.0.739 (R2012a) was employed to develop ANFIS models.

Performance Evaluation of ANFIS and ANN Models

To evaluate the accuracy of the ANN and ANFIS models, different criteria were used including correlation coefficient (R), root mean square error (RMSE), and mean absolute percentage error (MAPE). The performances of the models were assessed and compared to find the best prediction methods. The following formulas were employed:

$$R^2 = 1 - \left(\frac{\sum_{i=1}^n (P_i - A_i)^2}{\sum_{i=1}^n A_i^2} \right) \quad (3)$$

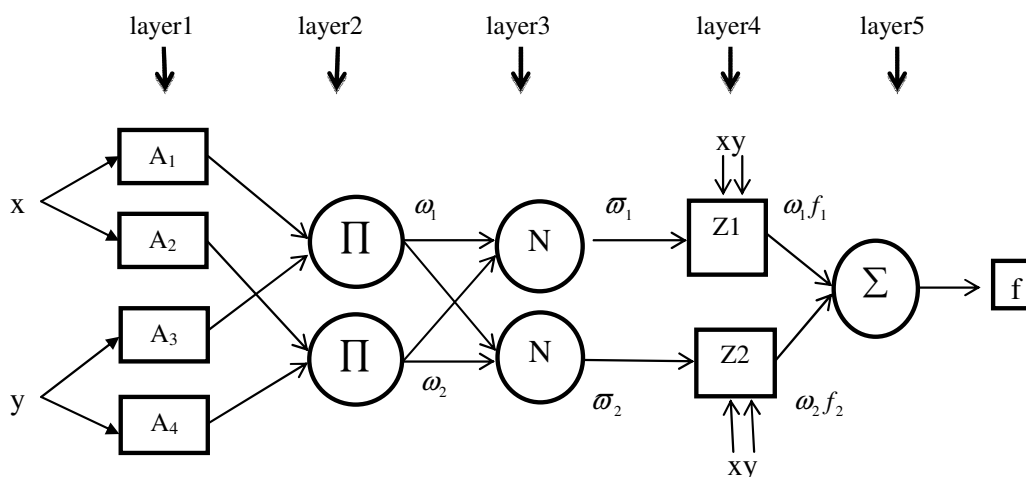

Figure 1. Adaptive neuro-fuzzy inference system structure.

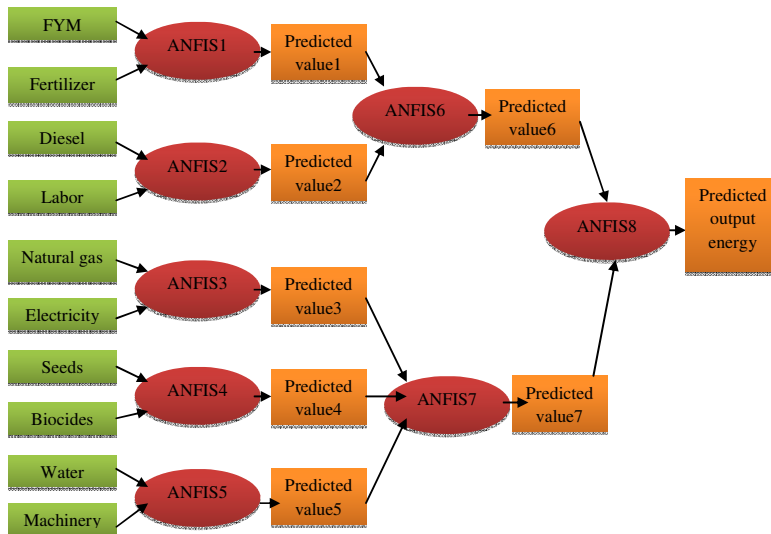

Figure 2. The first topology of ANFIS model to predict tomato yield.

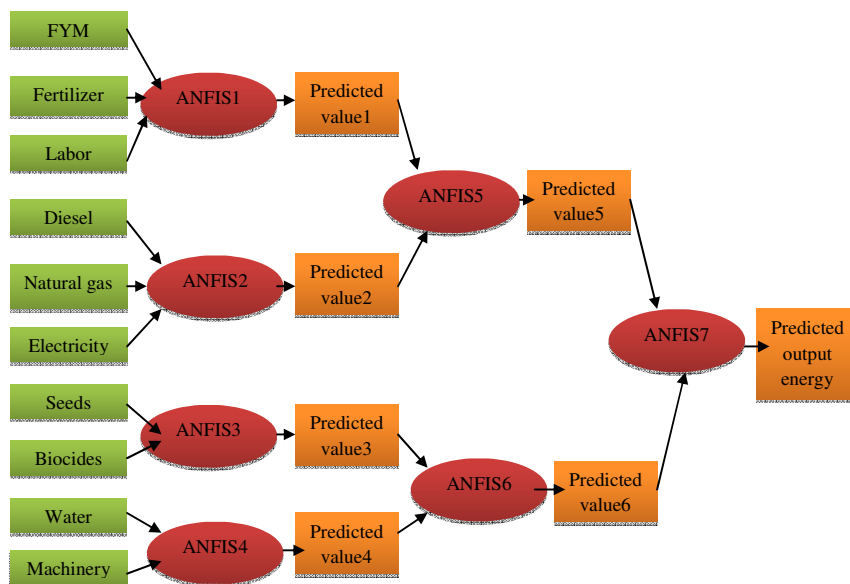

Figure 3. The second topology of ANFIS model to predict tomato yield.

$$RMSE = \sqrt{\frac{1}{n} \sum (P_i - A_i)^2} \quad (4)$$

$$MAPE = \frac{1}{n} \sum_{i=1}^n \left(\frac{|P_i - A_i|}{A_i} \times 100 \right) \quad (5)$$

Where, P_i and A_i are respective predicted and actual yield for the i th farmer and n is the number of the points in the data set (Khoshnevisan *et al.* 2014).

RESULTS AND DISCUSSION

Input-Output Energy Analysis

Energy inputs utilized by different operations during greenhouse tomato production in the studied area are summarized in Table 3. The results show that the total energy input was calculated as

1,316.1 GJ ha⁻¹. Among the all energy inputs, natural gas with amount of 853.2 GJ ha⁻¹ was the key input, followed by electricity and chemical fertilizers. Natural gas and electricity were, respectively, used by heaters and electric motors; this high contribution of natural gas and electricity showed the low efficiency of heating systems and electric pumps employed in production process. In a study conducted by Pahlavan *et al.* (2012), it was illustrated that diesel fuel and electricity were the most consumed energy inputs in greenhouse basil production. They emphasized that the diesel fuel was used by heating systems in the greenhouses. The same results were reported by Hatirli *et al.* (2006), Ozkan *et al.* (2011), Canakci and Akinici (2006) and Heidari *et al.* (2012) for different greenhouse crops production.

Direct and indirect energies were calculated as 1,240.8 and 75.25 GJ ha⁻¹, respectively, while renewable and nonrenewable energies were calculated as 14.21 and 1,301.93 GJ ha⁻¹, respectively. The researchers, who analyzed input-output energy in different greenhouse production in

Iran, reported that the share of nonrenewable energy in the total energy input was so substantial (Banaeian *et al.*, 2011; Pahlavan *et al.*, 2011; Omid *et al.*, 2011).

Improving the energy use efficiency of heating systems by employing more efficient heaters along with using thermostat in appropriate places in the greenhouses can help to reduce the high consumption of natural gas energy. Also, based on the high potential for using solar energy during the spring and summer, applying technology for creating electricity from solar energy can reduce the high consumption of nonrenewable energy in the studied area.

Analysis of GHG Emission

The amount of GHG emissions from different sources are shown in Table 4. The total emission was estimated as 34,758.1 kg CO₂eq ha⁻¹. The last column of Table 4 shows the standard deviation for each energy source. As can be observed, the amount of total emission varies from 21,769.7 to 42,167.6 CO₂eq

Table 3. Energy inputs and output for greenhouse tomato production (GJ ha⁻¹).

Item	Total energy equivalent (GJ ha ⁻¹)	Percentage (%)	SD ^a
A. inputs			
Machinery	1.16	0.1	0.09
Labor	6.16	0.5	1.55
Diesel fuel	8.26	0.6	1.67
Natural gas	853.17	66	126.22
Electricity	350.66	27	88.67
Chemical fertilizers			
Nitrogen (N)	22.74	1.7	4.97
Phosphate (P ₂ O ₅)	5.56	0.4	1.22
Potassium(K ₂ O)	4.3	0.3	0.94
Micro nutrients	20.37	1.6	5.32
FYM	4.51	0.3	1.42
Biocide	15.54	1.2	4.71
Water for irrigation	3.45	0.3	0.84
Seeds	10 ⁻⁴	0.0	0.00
Total energy input	1316.14	100	
B. output			
Tomato	218.1		31.11

^a Indicates standard deviation for energy inputs (GJ ha⁻¹).



ha⁻¹ on the basis of different amount of energy usage.

Figure 4 shows the contribution of energy inputs to GHG emission for greenhouse tomato production in the studied area. The results revealed that electricity with a share of 52.36% had a significant effect on GHG emission, followed by natural gas (42.77%). As mentioned above (Table 3), natural gas energy was the key factor from energy consumption point of view (2.5 times more than electricity energy), while the contribution of electricity to GHG emission was more noticeable, however, its energy equivalent was lower than that of natural gas. Accordingly, the use of natural gas and electrical energy should be reduced simultaneously.

ANN Models: Evaluation and Error Analysis

Several ANN models with different topologies and distinct learning algorithms were trained and developed and their performance was evaluated to find the best network. A variety of activation functions including logistic sigmoid, tangent sigmoid, as well as purelin transfer functions along with different number of hidden layers were practiced employing different number of neurons in each hidden layer. Performance of various ANN topologies for predicting output energy is summarized in Table 5. The best network consisted of one input layer with 10 neurons, three hidden layers with 20, 17 and 9 neurons in each one, and one output layer with one neuron. Tangent sigmoid transfer function was employed in

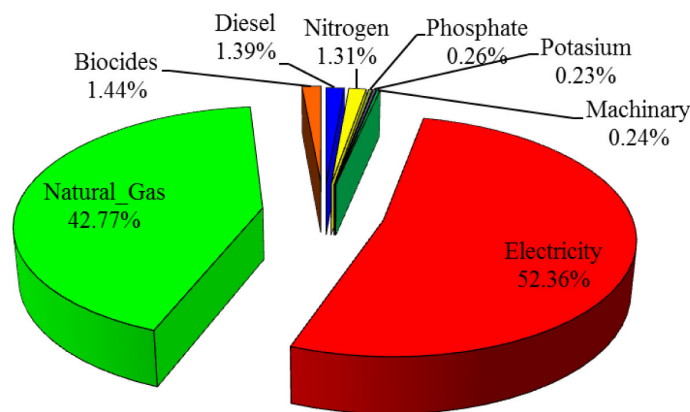

Figure 4. Contribution of energy inputs to GHG emission.

Table 4. Greenhouse gas emissions of inputs in tomato production.

Item	GHG emission (kg CO ₂ eq ha ⁻¹)	Max	Min	SD
Diesel	482.37	625.28	199.96	96.53
Chemical fertilizer				
N	456.68	693.33	315.71	97.78
P ₂ O ₅	91.34	138.67	63.14	19.56
K ₂ O	78.99	120.6	53.71	16.95
Biocide	501.27	715.20	303.6	91.24
Machinery	83.48	96.66	65.42	6.2
Electricity	18198.81	26627.14	7455.6	4518.83
Natural gas	14865.17	18608.2	11168.15	2167.47
Total emission	34758.11	42167.57	21769.67	4256.97

hidden layers and the output layer included purelin transfer function. As highlighted in Table 5, LM training algorithm produced the best result. R, RMSE, and MAPE for the best network architecture were calculated as, respectively, 0.933, 0.0514, and 0.279, which show that the network can appropriately predict energy output with respect to energy inputs.

Evaluation of ANFIS Models

Two main ANFIS architectures as well as four important modifications were made in order to find the best ANFIS topology. The modifications included the type of input and output MFs, the number of input and output MFs, learning algorithm, and the number of epochs.

The best results for the first ANFIS topology (see Figure 2) are illustrated in Table 6. As can be seen, hybrid learning method yielded the best result. Several studies, which have been conducted using ANFIS models, showed that hybrid method can produce better results than propagation learning algorithm (Bektas Ekici and Aksoy, 2011; Bagheri *et al.*, 2012; Ho and Tsai, 2011). For the best ANFIS architecture, Gbell and linear MFs were selected for input and output MFs, respectively.

One of the most necessary modifications relates to the number of MFs. The number of MFs determines the total number of parameters in the ANFIS network, which

should be fewer than the number of training data pairs. The ANFIS information of the first topology is summarized in Table 7. As can be seen, the number of training data pairs was 58, therefore, the number of MFs was chosen as 4,3 where two inputs entered into the model (ANFIS 1 to 6 and 8) and 2,2,2 where three inputs entered into the model (ANFIS 7). Accordingly, the total number of parameters was calculated as 57 and 50, which show the accuracy of the model.

The characteristics of the best structure of the second ANFIS architecture (see Figure 3) are demonstrated in Table 8. As can be seen, seven ANFIS networks were built to predict the output energy. The combination of Gbell and linear MFs as well as hybrid learning method yielded the best results. For ANFIS 1 and 2, where three input parameters entered into the network, the number of MFs was assessed as 2,2,2, while for other networks it was selected as 4,3.

Comparison between the two ANFIS topologies showed that both ANFIS architectures were able to predict the output energy accurately. Cross-correlation between predicted and observed output energies for the first and second ANFIS topologies are shown in Figure 5. MAPE for the first and second ANFIS models were calculated as 0.147 and 0.151, respectively, which show that the second ANFIS model can predict output energy with more accuracy.

Table 5. Performance of various ANN topologies for predicting output energy.

Activation function	Training algorithm	Neurons in hidden layer	R	RMSE	MAPE
tan/lin	Trainlm	22	0.923	0.0532	0.282
sig/lin	Trainlm	30-12	0.927	0.0538	0.291
tan/lin	Trainlm	20-17-9	0.933	0.0514	0.279
sig/lin	Traingd	18	0.931	0.0529	0.281
tan/lin	Traingd	16-25	0.918	0.0665	0.312
tan/lin	Traingd	32-10-19	0.924	0.0533	0.288
tan/lin	Traingdm	29	0.917	0.0635	0.298
sig/lin	Traingdm	12-32	0.929	0.0522	0.284
tan/lin	Traingdm	35-20-22	0.923	0.519	0.288



Table 6. The characteristics of the best structure of the third ANFIS architecture.

Item	Type of MF		Number of MF		Learning method	R	RMSE	MAPE (%)
	Input	Output	Input	Epoch				
ANFIS1	Gbell	Linear	4,3	40	Hybrid	0.76	0.091	0.523
ANFIS2	Gbell	Linear	4,3	40	Hybrid	0.809	0.081	0.468
ANFIS3	Gbell	Linear	4,3	40	Hybrid	0.716	0.096	0.598
ANFIS4	Gbell	Linear	4,3	40	Hybrid	0.68	0.102	0.641
ANFIS5	Gbell	Linear	4,3	40	Hybrid	0.776	0.087	0.501
ANFIS6	Gbell	Linear	4,3	40	Hybrid	0.93	0.051	0.304
ANFIS7	Gbell	Linear	2,2,2	40	Hybrid	0.942	0.046	0.278
ANFIS8	Gbell	Linear	4,3	40	Hybrid	0.982	0.026	0.151

Table 7. ANFIS information of the first topology.

ANFIS info	ANFIS 1, 2, 3, 4, 5, 6 and 8	ANFIS 7
Number of nodes	43	34
Number of linear parameters	36	32
Number of nonlinear parameters	21	18
Total number of parameters	57	50
Number of training data pairs	58	58
Number of checking data pairs	20	20
Number of fuzzy rules	12	8

Table 8. The characteristics of the best structure of the second ANFIS architecture.

Item	Type of MF		Number of MF		Learning method	R	RMSE	MAPE (%)
	Input	Output	Input	Epoch				
ANFIS1	Gbell	Linear	2,2,2	40	Hybrid	0.774	0.088	0.506
ANFIS2	Gbell	Linear	2,2,2	40	Hybrid	0.763	0.091	0.529
ANFIS3	Gbell	Linear	4,3	40	Hybrid	0.657	0.106	0.684
ANFIS4	Gbell	Linear	4,3	40	Hybrid	0.763	0.089	0.57
ANFIS5	Gbell	Linear	4,3	40	Hybrid	0.946	0.045	0.256
ANFIS6	Gbell	Linear	4,3	40	Hybrid	0.93	0.051	0.307
ANFIS7	Gbell	Linear	4,3	40	Hybrid	0.983	0.025	0.149

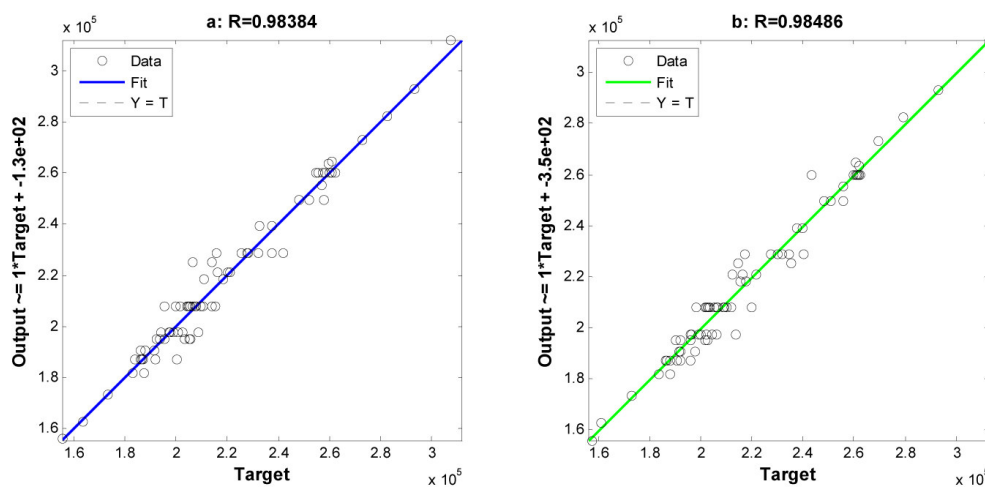

Figure 5. Cross-correlation between predicted and observed output energy for: (a) First ANFIS topology, and (b) Second ANFIS topology.

Comparison of ANN and ANFIS Models

The ANFIS models are composed of both ANN and fuzzy-logic model, therefore, they have the ability of working with uncertain noisy and imprecise data, especially those related in agricultural process, where data are generally inconstant and imprecise. Comparing the results obtained from ANN and ANFIS models revealed that ANFIS models were able to predict output energy more accurately than ANN models due to employing fuzzy rules. In a study carried out by Khashei-Siuki *et al.* (2011), ANFIS and ANN were exercised to predict dry-land wheat yield. They reported that ANFIS consistently produced better results than ANN.

CONCLUSION

The input-output energy analysis in greenhouse tomato production in Isfahan province showed that the total energy input was 1,316.1 GJ ha⁻¹ while the total energy output was 281.1 GJ ha⁻¹, which revealed that the energy use efficiency in the surveyed area was very low. Natural gas and electricity held the first and second rank among all energy inputs. Evaluations of GHG emission showed that the total GHG emission was about 34758.1 kg CO₂eq ha⁻¹ and, among all input, electricity played the most important role, followed by natural gas. The following methods and tips can help greenhouse holders to improve their energy use efficiency. Improvement of heating systems, applying more efficient electrical pumps for irrigation systems, supplying electricity from non-fossil resources, and providing the possibility of storage and application of rainfall water in the studied region are highly recommended. Deploying a retractable shade/energy curtain at night can significantly reduce heat loss by providing another insulating layer. Moreover, the nylon that was commonly used to cover greenhouses was not appropriate for winter season and should be

changed or a thicker nylon or an extra layer should be employed in order to minimize the loss of heat, which is presently squandered due to conduction. Most greenhouse holders are still not taking advantage of infrared (IR) plastic film on their greenhouses, which prevents heat provided by the heating system to be lost by conduction, convection, and radiation. Drawing a comparison between ANN and ANFIS models showed that, due to employing fuzzy rules, the ANFIS models could forecast output energy more accurately than ANN models. Accordingly, R, RMSE, and MAPE for the best ANFIS architecture were calculated as 0.983, 0.025, and 0.149, respectively, while these performance parameters for the best ANN model were computed as 0.933, 0.05414 and 0.279, respectively. Application of these models can help greenhouse holders in marketing their crops in advance and before the crop is available for selling.

ACKNOWLEDGEMENTS

The first author would like to thank the University of Tehran for giving their financial support; and the participating farmers. Also, this paper was financially supported by the University of Malaya under Grant RP005A-13ICT.

REFERENCES

1. Bagheri, M., Rajabi, M., Mirbagheri, M. and Amin, M. 2012. BPSO-MLR and ANFIS Based Modeling of Lower Flammability Limit. *J. Loss Prevent Proc.*, **25**: 373-382.
2. Banaeian, N., Omid, M. and Ahmadi, H. 2011. Energy and Economic Analysis of Greenhouse Strawberry Production in Tehran Province of Iran. *Eng. Convers. Manage.*, **52**:1020-1025.
3. Bektas Ekici, B. and Aksoy, U. T. 2011. Prediction of Building Energy Needs in Early Stage of Design by Using ANFIS. *Expert Syst. Appl.*, **38**: 5352-5358.
4. Benediktsson, J. A., Swain, P. H. and Ersoy, O. K. 1990. Neural Network Approaches versus Statistical Methods in Classification



- of Multisource Remote Sensing. *Trasact. Geosci. Remote Sens.*, **28**: 540-552.
5. Canakci, M. and Akinci, I. 2006. Energy Use Pattern Analyses of Greenhouse Vegetable Production. *Energy*, **31**: 1243-1256.
 6. FAO. 2012. *Food and Agriculture Organization*.
<http://faostat.fao.org/site/339/default.aspx>.
 7. Ghobadian, B., Rahimi, H., Nikbakht, A. M., Najafi, G. and Yusaf, T. F. 2009. Diesel Engine Performance and Exhaust Emission Analysis Using Waste Cooking Biodiesel Fuel with an Artificial Neural Network. *Renew. Energ.*, **34**: 976-982.
 8. Hatirli, S.A., Ozkan, B. and Fert, C. 2006. Energy Inputs and Crop Yield Relationship in Greenhouse Tomato Production. *Renew. Energ.*, **31**: 427-438.
 9. Heidari, M. D. and Omid, M. 2011. Energy Use Patterns and Econometric Models of Major Greenhouse Vegetable Productions in Iran. *Energy*, **36**: 220-225.
 10. Heidari, M. D., Omid, M. and Mohammadi, A. 2012. Measuring Productive Efficiency of Horticultural Greenhouses in Iran: A Data Envelopment Analysis Approach. *Expert Syst. Appl.*, **39**: 1040-1045.
 11. Ho, Y. -C. and C. -T. Tsai. 2011. Comparing ANFIS and SEM in Linear and Nonlinear Forecasting of New Product Development Performance. *Expert Syst. Appl.*, **38**: 6498-6507.
 12. Kaul, M., Hill, R. L. and Walthall, C. 2005. Artificial Neural Networks for Corn and Soybean Yield Prediction. *Agr. Syst.*, **85**: 1-18.
 13. Khashei-Siuki, A., Kouchakzadeh, M. and Ghahraman, B. 2011. Predicting Dryland Wheat Yield from Meteorological Data Using Expert System, Khorasan Province, Iran. *J. Agr. Sci. Tech.*, **13**: 627-640.
 14. Khoshnevisan, B., Bolandnazar, E., Barak, S., Shamshirband, S., Maghsoudlou, H., Altameem, T.A., Gani, A., A Clustering Model Based on an Evolutionary Algorithm for Better Energy Use in Crop Production. *Stoch. Environ. Res. Risk. Assess.*, 1-15.2015 (DOI 10.1007/s00477-014-0972-6).
 15. Khoshnevisan, B., Rajaeifar, M. A., Clark, S., Shamahirband, S., Anuar, N. B., Mohd Shuib, N. L., Gani, A., 2014. Evaluation of Traditional and Consolidated Rice Farms in Guilan Province, Iran, Using Life Cycle Assessment and Fuzzy Modeling. *Sci. Total. Environ.*, **481**: 242-251.
 16. Kitani, O. 1999. CIGR: Handbook of Agricultural Engineering. In: *"Energy Biomass Eng"*. ASAE Publication, St Joseph, MI, USA, PP.13-42.
 17. Lal, R. 2004. Carbon Emission from Farm Operations. *Environ. Int.*, **30**: 981-990.
 18. Lette, J., Colletti, B. W., Cerino, M., McNamara, D., Eybalin, M. C., Levasseur, A. and Nattel, S. 1994 Artificial Intelligence versus Logistic Regression Statistical Modelling to Predict Cardiac Complications after Noncardiac Surgery. *Clin. Cardiol.*, **17**: 609-614.
 19. Lim, Y., Moon, Y. -S. and Kim, T. -W. 2007. Artificial Neural Network Approach for Prediction of Ammonia Emission from Field-applied Manure and Relative Significance Assessment of Ammonia Emission Factors. *Eur. J. Agron.*, **26**: 425-434.
 20. Liu, M. and Ling, Y. Y. 2003. Using Fuzzy Neural Network Approach to Estimate Contractors' Markup. *Build. Environ.*, **38**: 1303-1308.
 21. Mousavi-Avval, S. H., Rafiee, S., Jafari, A. and Mohammadi, A. 2011. Optimization of Energy Consumption for Soybean Production Using Data Envelopment Analysis (DEA) Approach. *Appl. Energ.*, **88**: 3765-3772.
 22. Naderloo, L., Alimardani, R., Omid, M., Sarmadian, F., Javadikia, P., Torabi, M. Y. and Alimardani, F. 2012. Application of ANFIS to Predict Crop Yield Based on Different Energy Inputs. *Measurement*, **45**: 1406-1413.
 23. Najafi, G., Ghobadian, B., Tavakoli, T., Buttsworth, D. R., Yusaf, T. F. and Faizollahnejad, M. 2009. Performance and Exhaust Emissions of a Gasoline Engine with Ethanol Blended Gasoline Fuels Using Artificial Neural Network. *Appl. Energ.*, **86**: 630-639.
 24. Nassiri1, S. M. and Singh, S. 2010. A Comparative Study of Parametric and Non-Parametric Energy Use Efficiency in Paddy Production. *J. Agr. Sci. Tech.*, **12**: 391-399.
 25. Nemecek, T. and Kagi, T. 2007. Life Cycle Inventories of Agricultural Production Systems. Agroscope Reckenholz, Tanikon Research Station ART, Zurich and Dubendorf.

26. Omid, M., Ghojabeige, F., Delshad, M. and Ahmadi, H. 2011. Energy Use Pattern and Benchmarking of Selected Greenhouses in Iran Using Data Envelopment Analysis. *Energ. Convers. Manage.*, **52**: 153-162.
27. Ozkan, B., Ceylan, R. F. and Kizilay, H. 2011. Energy Inputs and Crop Yield Relationships in Greenhouse Winter Crop Tomato Production. *Renew. Energ.*, **36**: 3217-3221.
28. Pahlavan, R., Omid, M. and Akram, A. 2011. Energy Use Efficiency in Greenhouse Tomato Production in Iran. *Energy*, **36**: 6714-6719.
29. Pahlavan, R., Omid, M. and Akram, A. 2012. Application of Data Envelopment Analysis for Performance Assessment and Energy Efficiency Improvement Opportunities in Greenhouses Cucumber Production. *J. Agr. Sci. Tech.*, **14**: 1465-1475.
30. Pahlavan, R., Omid, M. and Akram, A. 2012. Energy Input-output Analysis and Application of Artificial Neural Networks for Predicting Greenhouse Basil Production. *Energy*, **37**: 171-176.
31. Pahlavan, R., Omid, M. and Akram, A. 2012. The Relationship between Energy Inputs and Crop Yield in Greenhouse Basil Production. *J. Agr. Sci. Tech.*, **14**: 1243-1253.
32. Petković, D., Pavlović, N. T., Shamshirband, S., Mat Kiah, M. L., Badrul Anuar, N. and Idna Idris, M. Y. 2014. Adaptive Neuro-fuzzy Estimation of Optimal Lens System Parameters. *Opt. Laser Eng.*, **55**: 84-93.
33. Pishgar-Komleh, S. H., Ghahderijani, M. and Sefeedpari, P. 2012. Energy Consumption and CO₂ Emissions Analysis of Potato Production Based on Different Farm Size Levels in Iran. *J. Clean Prod.*, **33**: 183-191.
34. Rafiee, S., Mousavi Avval, S. H. and Mohammadi, A. 2010. Modeling and Sensitivity Analysis of Energy Inputs for Apple Production in Iran. *Energy*, **35**: 3301-3306.
35. Razi, M. A. and Athappilly, K. 2005. A Comparative Predictive Analysis of Neural Networks (NNs), Nonlinear Regression and Classification and Regression Tree (CART) Models. *Expert Syst. Appl.*, **29**: 65-74.
36. Safa, M. and Samarasinghe, S. 2011. Determination and Modelling of Energy Consumption in Wheat Production Using Neural Networks: "A Case Study in Canterbury Province, New Zealand". *Energy*, **36**: 5140-5147.
37. Shamshirband, S., Kalantari, S. and Bakhshandeh, Z. 2010. Designing a Smart Multi-agent System Based on Fuzzy Logic to Improve the Gas Consumption Pattern. *Sci. Res. Essays*, **5**: 592-605.
38. Shamshirband, S., Petković, D., Čojbašić, Ž., Nikolić, V., Anuar, N. B., Mohd Shuib, N. L., Mat Kiah, M. L. and Akib, S. 2014. Adaptive Neuro-fuzzy Optimization of Wind Farm Project Net Profit. *Energ. Convers. Manage.*, **80**: 229-237.
39. Singh, H., Mishra, D. and Nahar, N. M. 2002. Energy Use Pattern in Production Agriculture of a Typical Village in Arid Zone, India. Part I. *Energ. Convers. Manage.*, **43**: 2275-2286.
40. Tabatabaie, S. M. H., Rafiee, S., Keyhani, A. and Ebrahimi, A. 2013. Energy and Economic Assessment of Prune Production in Tehran Province of Iran. *J. Clean Prod.*, **39**: 280-284.



مقایسه شبکه‌های عصبی مصنوعی و سیستم استنتاج فازی-عصبی برای مدل‌سازی انرژی مصرفی در تولید گوجه فرنگی گلخانه‌ای - مطالعه موردی در استان اصفهان

ب. خوشنویسان، ش. رفیعی، ش. شمشیربند، م. امید، ج. اقبال، ن. بدرل انوار، و ا.و. عبدال الوهاب

چکیده

در این مطالعه تولید گوجه‌فرنگی گلخانه‌ای از منظر انرژی مصرفی و انتشار گازهای گلخانه‌ای مورد مطالعه قرار گرفت. همچنین شبکه‌های عصبی مصنوعی و سیستم استنتاج فازی-عصبی به منظور مدل‌سازی انرژی مصرفی مورد استفاده قرار گرفتند. انرژی ورودی و خروجی کل به ترتیب ۱۳۱۶ و ۲۸۱ کیلووات‌ساعت محاسبه گردید. در بین تمامی نهاده‌های ورودی بیشترین سهم از آن گاز طبیعی و الکتریسیته بوده است. ارزیابی انتشار گازهای گلخانه‌ای نشان داد که کل گاز منتشر شده برابر بوده است با $34758 \text{ CO}_2\text{eq ha}^{-1}$ و الکتریسیته مصرفی بیشترین سهم را در این انتشار داشته است. مقایسه شبکه‌های عصبی مصنوعی و سیستم استنتاج فازی عصبی نشان داد که انفیس به دلیل بهره‌گیری از قوانین فازی قادر بود تا با دقت بیشتری مدل‌سازی را انجام دهد. بر این اساس R ، $RMSE$ و $MAPE$ برای بهترین انفیس به ترتیب ۰/۹۸۳، ۰/۰۲۵ و ۰/۱۴۹ محاسبه گردید در حالی که این پارامترها برای شبکه عصبی مصنوعی برابر بودند با ۰/۹۳۳، ۰/۰۵۴۱ و ۰/۲۷۹.