

## Comparative Reproductive Performance of *Helicoverpa armigera* (Hübner) (Lepidoptera: Noctuidae) Reared on Thirteen Soybean Varieties

B. Naseri<sup>1</sup>, Y. Fathipour<sup>1\*</sup>, S. Moharramipour<sup>1</sup>, and V. Hosseininaveh<sup>2</sup>

### ABSTRACT

Reproduction parameters for *Helicoverpa armigera* (Hübner) were determined and compared on 13 soybean varieties (DPX, L17, BP, Clark, JK, 356, M4, M7, M9, Gorgan3, Sahar, Zane and Williams) at 25±1°C, 65±5% RH over a photoperiod of 16:8 (L:D) hours. Reproduction parameters were estimated for individual newly emerged moths, which had spent their immature stages on different soybean varieties. The highest rate of gross fecundity was on M4 (2,238 eggs female<sup>-1</sup>), whereas the lowest value of this parameter was on Gorgan3 (467 eggs female<sup>-1</sup>). The gross fertility rate was the highest on M7 (782 eggs female<sup>-1</sup>) and lowest on Gorgan3 (149 eggs female<sup>-1</sup>). The net fecundity rate varied from 192 (BP) to 1,275 eggs (M7). The net fertility rate was the highest on M7 (586 eggs female<sup>-1</sup>) and lowest on Sahar (56 eggs female<sup>-1</sup>). The daily number of eggs laid per female ranged from 50 to 282 eggs, the minimum on Gorgan3 and the maximum on M4. Our results demonstrated that M9, Williams, Clark, L17, M7, M4 and Zane varieties were more suitable host plants for reproduction of the studied population of *H. armigera*. The other varieties examined showed less suitability as host plants for *H. armigera* reproduction.

**Keywords:** *Helicoverpa armigera*, Reproduction parameters, Resistance, Soybean varieties.

### INTRODUCTION

*Helicoverpa armigera* (Hübner) (Lepidoptera: Noctuidae) is a major pest of a wide range of economically important plants including field and horticultural crops in Iran (Farid, 1986) and throughout the world (Jallow *et al.*, 2004; Reddy *et al.*, 2004; Yu *et al.*, 2008; Mironidis and Savopoulou-Soultani, 2008). In northwest Iran, *H. armigera* completes three or four generations per year, especially on soybean, and causes significant damage to this crop. The larvae of this pest also attack tomato, cotton, corn, chick pea and bean in Iran. The pest status of this species is derived, in part, from its four life history characteristics

(namely, polyphagy, high mobility, high fecundity and a facultative diapause) that enable it to survive in unstable habitats and adapt to seasonal changes (Fitt, 1989).

The development, survival, reproduction and life table parameters of insects are influenced by host plant type (Tsai and Wang, 2001; Kim and Lee, 2002; Li *et al.*, 2004); while suitability of plants for the growth and development of phytophagous insects is an important factor for the establishment of pest population on a crop plant. The physical and volatile signals emanating from plants attract the insect to its surface whereas chemical and nutritional factors of the food substrate determine consumption, development and survival in

<sup>1</sup> Department of Entomology, Faculty of Agriculture, Tarbiat Modares University, P. O. Box: 14115-336, Tehran, Islamic Republic of Iran.

<sup>2</sup> Department of Plant Protection, College of Agricultural Sciences and Natural Resources, University of Tehran, Karaj, Islamic Republic of Iran.

\*Corresponding author, e-mail: fathi@modares.ac.ir



the larval stages and egg production of subsequent adults (Singh and Mullick, 1997).

Despite the economic importance of *H. armigera*, no information is available concerning the reproduction of this pest on different soybean varieties, although various biological studies have been conducted on the effect of different temperatures on the biological parameters (including fecundity) of *H. armigera* (Jallow and Matsumura, 2001; Mironidis and Savopoulou-Soultani, 2008) or the life table parameters of this pest on various host plants (Liu *et al.*, 2004). Here we provide new insights on the effects of different soybean varieties as larval food on the reproduction of adult *H. armigera*.

The effect of six different host plants on the fecundity of *H. armigera* females was determined by Liu *et al.* (2004) under laboratory conditions. They suggested that females emerging from the larvae fed on common bean laid more eggs than the larvae reared on other host plants examined. Dhandapani and Balasubramanian (1980) studied the development and reproduction of *H. armigera* on different food plants including cotton, pigeon pea and soybean, while the comparative aspects of the biology of *H. armigera* on different food substrates has been studied in India (Borah and Dutta, 2002; Kulkarni *et al.*, 2004). Host selection behavior and reproductive performance of Japanese *H. armigera* on an artificial diet and different crops including okra, tomato, eggplant, pepper and maize were studied by Jallow *et al.* (2001), who reported that the highest fecundity per female was on an artificial diet and the lowest one was on maize. The effect of egg load on the host selection behaviour of *H. armigera* was determined under laboratory conditions (Jallow and Zalucki, 1998).

Our objective here was to compare the reproduction parameters of *H. armigera* reared on different soybean varieties to understand the effect of these varieties on the reproductive capacity of this pest in order to develop a comprehensive pest management program for soybean in Iran.

## MATERIALS AND METHODS

### Plants

Seeds from the 13 soybean (*Glycine max* (L.) Merrill) varieties including 356 (Delsoy4210), M4, M7, M9, Clark, Sahar, JK, BP, Williams, L17, Zane, Gorgan3 and DPX were obtained from Plant and Seed Modification Research Institute. They were planted in the research field of Tarbiat Modares University in the suburbs of Tehran, Iran, in May 2007. For this study, the leaves and pods of different soybean varieties were transferred to a growth chamber at 25±1°C, 65±5% RH and for a photoperiod of 16:8 (L:D) hours. The leaves were used for feeding first instar larvae and pods were used for feeding 2<sup>nd</sup>-5<sup>th</sup> instar larvae.

The varieties chosen were common ones grown in Iran (DPX, Williams, Sahar, Gorgan 3, JK and BP). The others, Clark, M4, M7, M9 and 356 were more experimental varieties and L17 and Zane were exceptional cultivated varieties (Table 1).

### Insect Rearing

A laboratory colony of *H. armigera* was established in July 2007 from larvae collected from cotton fields in the Moghan region located in northwest of Iran. The stock culture was initiated on an artificial diet (cowpea powder 205 g, powdered agar 14 g, ascorbic acid 3.5 g, sorbic acid 1.1 g, methyl-4-hydroxybenzoate 2.2 g, yeast 35 g, wheat germ powder 30 g, formaldehyde 37% 2.5 mL, vegetable oil 5 mL and distilled water 650 mL). The insects examined on different soybean varieties had already been reared for two generations on the same varieties. The colony was supplemented, from time to time, with larvae collected from the field in order to reduce any inbreeding effects and to maintain the vigor of the colony. All experimental insects were kept inside a

**Table 1.** Planting areas of different soybean varieties in four provinces of Iran.

Province	Overall soybean planting area (ha)	Variety	Variety planting area (ha)
Golestan	45000-50000	DPX	7000-8000
		Williams	15000
		Sahar	20000
		Gorgan3	5000-6000
Mazandaran	20000-30000	Sahar	7000-8000
		JK	7000
		BP	5000
Lorestan	700	Clark	50
		M7, M9, M11	350
Ardabil (Moghan Region)	6000	Williams	5000
		L17	500
		Zane	500

growth chamber at  $25\pm 1^\circ\text{C}$ ,  $65\pm 5\%$  RH for a photoperiod of 16:8 (L:D) hours.

### Experiments

Adult moths that emerged from larvae reared on soybean varieties were used in the experiments. In order to obtain the same aged eggs of the pest, 10-15 pairs of both sexes of the moth reared on related varieties were kept inside a container (14 cm in diameter and 19 cm in height), which was closed at the top with a fine mesh net. Eggs laid within 12 hours were collected from the container and were used for the experiments. Newly hatched first-instar larvae (within 12 hours) were transferred individually into plastic Petri dishes (8 cm in diameter and 2 cm in height) with a hole covered by a fine mesh net for ventilation, containing the fresh leaves of different test plants. The petioles of detached leaves were inserted in water-soaked cotton to maintain freshness. The 2<sup>nd</sup> to 5<sup>th</sup> instars were reared on the pods of different soybean varieties. A fine camel hair brush was used for transferring younger larvae to the Petri dishes. Fresh food material was provided daily, when observations were recorded for the mortality/survival of larvae in the same instar or moulting in the next instar through pupation and adult emergence. Larval instars were determined by checking for shed head

capsules. Fifth instar larvae were kept in plastic containers (3 cm in diameter and 5 cm in height) for pre-pupation and pupation. Larval, pre-pupal and pupal periods and their mortality were recorded on different soybean varieties.

After emergence of the adults from larvae fed on different soybean varieties, one female and one male (15 replicates for each) were placed into each transparent plastic container (14 cm in diameter and 19 cm in height), which was closed at the top with a fine mesh net for ventilation and the internal walls covered with the same mesh net as an oviposition substrate. A small cotton wick soaked in 10% honey solution was placed in the containers to provide a source of carbohydrate for adult feeding. The main reproduction parameters of *H. armigera* were recorded until the death of the last female of the cohort.

The reproduction parameters as calculated for *H. armigera* from the daily egg counts were: gross fecundity rate (GFR), gross fertility rate (GFrR), gross hatch rate (GHR), net fecundity rate (NFR), net fertility rate (NFrR), daily eggs laid per female and daily fertile eggs laid per female on different varieties was estimated using the following equations (Carey, 1993):

$$\text{Gross fecundity rate} = \sum_{x=\alpha}^{\beta} M_x$$



$$\text{Gross fertility rate} = \sum_{x=\alpha}^{\beta} M_x h_x$$

$$\text{Gross hatch rate} = \sum_{x=\alpha}^{\beta} M_x h_x / \sum_{x=\alpha}^{\beta} M_x$$

$$\text{Net fecundity rate} = \sum_{x=\alpha}^{\beta} L_x M_x$$

$$\text{Net fertility rate} = \sum_{x=\alpha}^{\beta} L_x M_x h_x$$

$$\text{Daily eggs per female} = \sum_{x=\alpha}^{\beta} M_x / (\varepsilon - \omega)$$

$$\text{Daily fertile eggs per female} =$$

$$\sum_{x=\alpha}^{\beta} M_x h_x / (\varepsilon - \omega)$$

where,  $L_x$  is the days lived in interval  $x$  and  $x+1$ ,  $M_x$  is the average number of offsprings produced by females at age  $x$  and  $h_x$  is the hatching rate;  $\alpha$  is the age of female at the first oviposition and  $\beta$  is the age of female at the last oviposition and  $\varepsilon - \omega$  is the female longevity.

### Statistical Analysis

The effects of different soybean varieties on the reproduction parameters of *H. armigera* were subjected to one-way ANOVA to determine the similarities or significant differences using the statistical software Minitab 14. Statistical differences among the means were evaluated using the least significant differences (LSD) test at  $\alpha = 0.05$ . A logarithmic transformation  $\log_{10}(x+1)$  of the data was used to avoid heterogeneity of variance: untransformed means are presented in the table. Differences in each parameter value on the soybean varieties were tested for significance by estimating variances through the jackknife procedure (Meyer et al., 1986; Maia et al., 2000). This procedure is mainly used to estimate the variance between and bias of estimators. The steps for the application of the method were as follows:

a) Estimation of each reproduction parameter using the survival and fecundity data from all of the  $n$  females, referred to as

the true calculation. At this point, called step zero, the estimates obtained are denoted as  $GFR_{(all)}$ ,  $GFR_{(i)}$ ,  $NFR_{(all)}$ ,  $NFR_{(i)}$ , etc.

b) The procedure described in part (a) is repeated for  $n$  times, each time excluding a different female. In so doing, in each step  $i$ , data of  $n-1$  females are taken to estimate the parameters for each step, now named  $GFR_{(i)}$ ,  $GFR_{(i)}$ ,  $NFR_{(i)}$ ,  $NFR_{(i)}$ , etc.

c) In each step  $i$ , pseudo-values are calculated for each parameter, subtracting the estimate in step zero from the estimate in step  $i$ . For instance, the pseudo-values of  $GFR_{(j)}$  were calculated for the  $n$  samples using the following equation:

$$GFR_{(j)} = n \times GFR_{(all)} - (n-1) \times GFR_{(i)}$$

d) After calculating all of the  $n$  pseudo-values for  $GFR$ , jackknife estimates of the mean,  $GFR_{(mean)}$ , variance,  $VARGFR_{(mean)}$ , and standard error,  $SEGFR_{(mean)}$ , were calculated by the following equations:

$$GFR_{(mean)} = \frac{\sum_{j=1}^n GFR_{(j)}}{n}$$

$$VARGFR_{(mean)} = \frac{\sum_{j=1}^n (GFR_{(j)} - GFR_{(all)})^2}{n-1}$$

$$SEGFR_{(mean)} = \sqrt{\frac{VARGFR_{(mean)}}{n}}$$

For mean values of  $(n-1)$ , jackknife pseudo-values for each variety were subjected to an analysis of variance (Taghizadeh et al., 2008).

A dendrogram of soybean varieties based on reproduction parameters of *H. armigera* reared on different soybean varieties was constructed after cluster analysis by Ward's method using the statistical software SPSS 14.0.

## RESULTS

### Reproduction Parameters

The reproduction parameters of adults emerged from the larvae reared on different

**Table 2.** Reproduction parameters (Mean±SE) of *Helicoverpa armigera* on different soybean varieties.

Variety	Parameter			
	Gross fecundity rate	Gross fertility rate	Net fecundity rate	Net fertility rate
M7	2014±323.5 a	782±270.1 a	1275±106.6 a	586±49.0 a
JK	578±81.7 fg	196±29.9 de	392±34.2 bc	119±9.6 d
Clark	1512±187.8 abc	423±52.6 abc	783±147.8 b	219±41.4 cd
M4	2238±369.7 a	712±198.7 a	816±229.4 b	372±154.6 bc
M9	1723±291.3 abc	517±87.4 ab	604±71.2 b	198±12.4 cd
L17	2006±402.3 ab	542±108.6 ab	619±222.4 b	212±45.1 cd
356	1114±185.3 cde	279±46.3 cd	790±263.3 b	168±61.2 d
DPX	1159±184.0 bcd	313±49.7 bcd	503±118.5 bcd	164±32.8 cd
BP	745±76.7 def	290±29.9 bcd	192±47.3 d	58±7.3 e
Zane	1578±302.5 bc	458±87.7 abc	718±241.9 b	251±86.7 cd
Sahar	708±143.7 ef	162±40.7 e	269±96.2 d	56±16.4 e
Gorgan3	467±147.3 g	149±42.6 e	364±80.4 bcd	204±65.3 cd
Williams	1660±240.0 abc	448±64.8 abc	536±233.7 cd	221±66.3 cd

soybean varieties were significantly different (Table 2,  $P < 0.01$ ). The gross hatch rate of *H. armigera* was 25, 26, 46, 30, 28, 19, 31, 39, 27, 27, 29, 27 and 27 % on 356, M4, M7, M9, Clark, Sahar, JK, BP, Williams, L17, Zane, Gorgan3 and DPX, respectively. The highest rate of gross fecundity was on M4 (2,238 eggs female<sup>-1</sup>), whereas the lowest value of this parameter was on Gorgan3 (467 eggs female<sup>-1</sup>). Among different soybean varieties, the gross fertility rate was the highest on M7 (782 eggs female<sup>-1</sup>) and lowest on Gorgan3

(149 eggs female<sup>-1</sup>). The net fecundity rate varied from 192 to 1,275 eggs, which was highest on M7 and lowest on BP. The net fertility rate was highest on M7 (586 eggs female<sup>-1</sup>) and lowest on Sahar (56 eggs female<sup>-1</sup>).

The daily number of eggs laid per female ranged from 50 to 282 eggs, the minimum on Gorgan3 and the maximum on M4 (Figure 1). However, the number of fertile eggs laid per female was the highest on L17 (60 eggs) and lowest on Gorgan3 (14 eggs) (Figure 2).

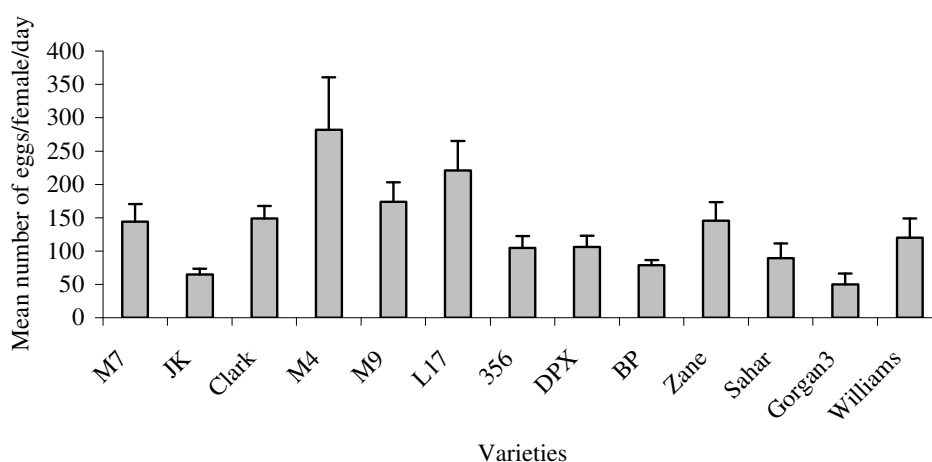
**Figure 1.** Mean daily number of eggs laid by *Helicoverpa armigera* reared on different soybean varieties.

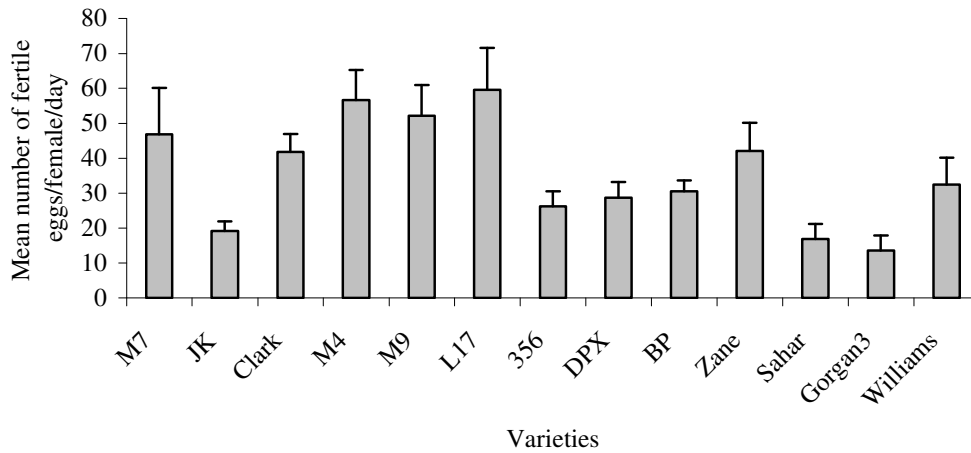

Figure 2. Mean daily number of fertile eggs laid by *Helicoverpa armigera* reared on different soybean varieties.

### Cluster Analysis

The dendrogram of soybean varieties based on the reproduction parameters of *H. armigera* reared on these varieties, revealed two distinct clusters, A and B (Figure 3). Cluster A (susceptible group) included three subclusters A1 (M9, Williams, Clark and L17), A2 (Zane) and A3 (M7 and M4).

Cluster B consisted of the BP, Sahar, JK, 356, DPX and Gorgan3 varieties (partially resistant group).

### DISCUSSION

Plant species differ greatly in suitability as hosts for specific insects when measured in terms of survival, development and

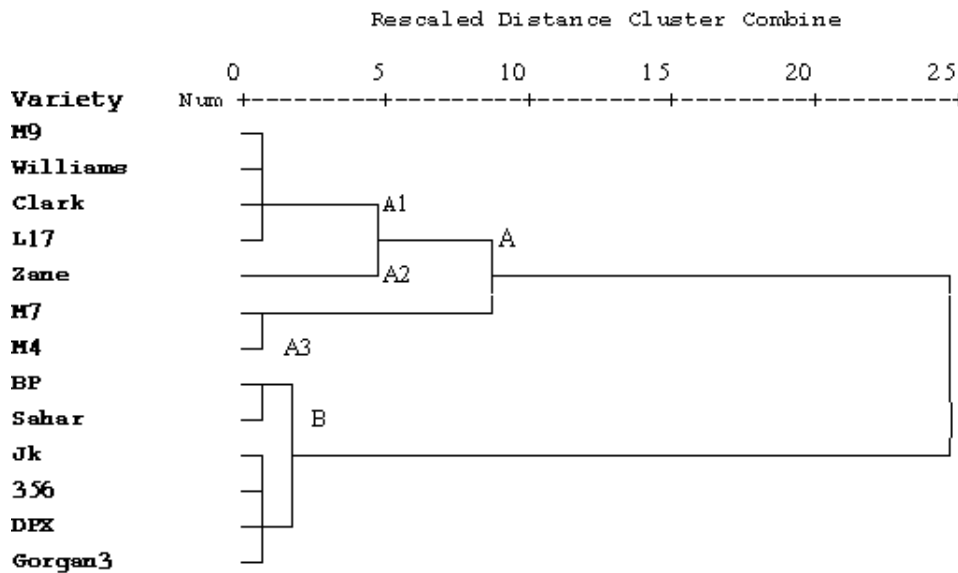

Figure 3. Dendrogram of different soybean varieties based on reproduction parameters of *Helicoverpa armigera* reared on these varieties.

reproductive rates. The shorter developmental time and greater total reproduction of insects on a host plant indicate greater suitability of that plant (van Lenteren and Noldus, 1990). Using plant resistant varieties is one of the core strategies of integrated pest management and secondary substances of plants or allelochemicals play a major role in plant resistance to pests (Wilson and Huffaker, 1976).

Understanding the reproduction parameters of a pest is one of the essential components in developing an integrated pest management strategy. Fecundity and adult longevity in *Helicoverpa* species are influenced by larval and adult nutrition, temperature and humidity (Adjei-Mafo and Wilson, 1983; Liu *et al.*, 2004). Host plant specificity and oviposition motivation are affected by the physiological state of *H. armigera* including age, feeding status, mated status and egg load (Jallow and Zalucki, 1998).

The reproduction parameters of *H. armigera* were affected by different soybean varieties. Females reared as larvae on the M4 and M7 varieties had a higher rate of fecundity and fertility than those reared on the other soybean varieties, suggesting that they are more susceptible to this pest as compared with the other varieties examined. Our previous research (Naseri *et al.*, 2009) showed that the larval period and development time of *H. armigera* were shorter on M7 than on the other varieties and this variety was a more suitable host plant for development of the immature stages. The data obtained in that study on M7 as a susceptible variety was in agreement with the finding of the current research on the reproduction performance of *H. armigera*. Variation in the reproduction parameters of the pest on different soybean varieties could be the result of differences in plant quality, either reflected in a difference in nutrients required by the pest or differences in the levels of secondary compounds. The unsuitability of some varieties as a host plant of *H. armigera* may be due to the presence

of some phytochemicals in these varieties acting as antixenotic and/or antibiotic agents or the absence of primary nutrients essential for the growth and development of *H. armigera* (Naseri *et al.*, 2009). The gross fecundity rate of *H. armigera* ranged from 467 to 2,736 eggs on Gorgan3 and M4, respectively. According to the results of Mironidis and Savopoulou-Soultani's (2008) studies, the gross fecundity rate of *H. armigera* was 1,008 eggs on an artificial diet based on maize meal at 25°C. Fecundity per female of *H. armigera* varied from 285 eggs on maize to 743 eggs on an artificial diet (Jallow *et al.*, 2001). Some possible reasons for such disagreement may be due to physiological differences depending on the type of host, genetic differences as a result of laboratory rearing or variation in geographic populations of the pest. Our finding on the number of daily eggs laid per female per day on Gorgan3 (50 eggs) is almost the same as the observation reported on an artificial diet (49 eggs) at 25°C (Mironidis and Savopoulou-Soultani, 2008).

In cluster analysis, the grouping of different soybean varieties within each cluster might be due to a high level of physiological similarity of soybean varieties in each cluster, and vice versa. The results of the comparison of reproduction parameters of *H. armigera* on different soybean varieties revealed that the clusters A (M9, Williams, Clark, L17, Zane, M7 and M4) and B (BP, Sahar, JK, 356, DPX and Gorgan3) were found to be the most suitable and unsuitable host plants, respectively, for reproduction of *H. armigera*. In conclusion, cluster A included the host plants susceptible due to the higher reproduction parameters of *H. armigera* reared on varieties grouped in this cluster. However, the varieties grouped in cluster B had the most resistance as host plants for *H. armigera* because of the lower reproduction parameters in these soybean varieties.

There are many factors affecting host suitability, including nutrient content and secondary substances of the host and the digestive and assimilation capability of an



insect (Scriber and Slansky, 1981; Smith, 1992). Through this research, we may be able to determine the population dynamics of the pest on different host varieties and use the information to manage the pest population below the economic injury level.

It has also been shown that the quality and quantity of nourishment ingested by an insect can directly affect its survival and reproduction (van Steenis and El-khawass, 1995; Du et al., 2004). So, fitness of the plant-feeding insects depends upon the nutrients in their host plant. However, the partially resistant varieties also may enhance the effectiveness of natural enemies and insecticides. Thus, the use of resistant varieties can be part of the development of biological and chemical control methods as a part of an IPM strategy (Du et al., 2004; Razmjou et al., 2006; Adebayo and Omoloyo, 2007).

In view of the agricultural policies in Iran to expand oilseed crops, especially soybean, it is necessary to study on resistance level of cultivated soybean varieties to different pests particularly to *H. armigera*. Since plants have an assortment of defensive genes whose products are noxious to insects and pathogens, the finding of genes encoding defensive factors from soybean varieties or other uncultivated plant species and the transformation of these genes to commercially cultivated crops would be useful to enhance plant resistance to *H. armigera*.

#### ACKNOWLEDGEMENTS

This research was in part supported by a grant from the Center of Excellence for Integrated Pests and Diseases Management of Oil Crops of Iran, which is greatly appreciated.

#### REFERENCES

1. Adebayo, A. and Omoloyo, S. V. 2007. Abundance of 24-methylenecholesterol in Traditional African Rice as an Indicator of Resistance to the African Rice Gall Midge, *Orseolia oryzivora* Harris and Gagne. *Entomol. Sci.*, **10**:249-257.
2. Adjei-Mafo, I. K. and Wilson, L. T. 1983. Association of Cotton Nectar Production with *Heliothis punctigera* (Lepidoptera: Noctuidae) Oviposition. *Environ. Entomol.*, **12**:1166-1170.
3. Borah, S. R. and Dutta, S. K. 2002. Biology of Gram Pod Borer, *Helicoverpa armigera* (Hub.) on Pigeon Pea. *J. Agric. Sc. Soc. NE. India.*, **15**:34-37.
4. Carey, J. R. 1993. Applied Demography for Biologists, with Special Emphasis on Insects. Oxford University Press, U. K., 211 PP.
5. Dhandapani, N. and Balasubramanian, M. 1980. Effect of Different Fod Plants on the Development and Reproduction of *Heliothis armigera* (Hübner). *Experientia Basel Birkhauser.*, **36**:930-931.
6. Du, L., Ge, F., Zhu, S. and Parajulee, M. N. 2004. Effect of Cotton Cultivar on Development and Reproduction of *Aphis gossypii* (Homoptera: Aphididae) and Its Predator *Propylaea japonica* (Coleoptera: Coccinellidae). *J. Econ. Entomol.*, **97**:1278-1283.
7. Farid, A. 1986. Study of Bollworm *Heliothis armigera* (Hub.) on Tomato in Jyroft and Kahnuj. *Appl. Entomol. Phytopathol.*, **54**:15-24.
8. Fitt, G. P. 1989. The Ecology of *Heliothis* in Relation to Agroecosystems. *Annu. Rev. Entomol.*, **34**:17-52.
9. Jallow, M. F. A. and Matsumura, M. 2001. Influence of Temperature on the Rate of Development of *Helicoverpa armigera* (Hübner) (Lepidoptera: Noctuidae). *Appl. Entomol. Zool.*, **36**:427-430.
10. Jallow, M. F. A. and Zalucki, M. P. 1998. Effect of Egg Load on the Host-selection Behaviour of *Helicoverpa armigera* (Hübner) (Lepidoptera: Noctuidae). *Australian J. Zool.*, **46**: 291-299.
11. Jallow, M. F. A., Cunningham, J. P. and Zalucki, M. P. 2004. Intra-specific Variation for Host Plant Use in *Helicoverpa armigera* (Hübner) (Lepidoptera: Noctuidae): Implications for Management. *Crop Protec.*, **23**: 955-964.
12. Jallow, M. F. A., Matsumura, M. and Suzuki, Y. 2001. Oviposition Preference and Reproductive Performance of Japanese



- Helicoverpa armigera* (Hübner) (Lepidoptera: Noctuidae). *Appl. Entomol. Zool.*, **36**: 419-426.
13. Kim, D. S. and Lee, J. H. 2002. Egg and Larval Survivorship of *Carposina sasakii* (Lepidoptera: Carposinidae) in Apple and Peach and Their Effects on Adult Population Dynamics on Orchards. *Environ. Entomol.*, **31**:686-692.
  14. Kulkarni, U. S., Gawande, R. B., Kulkarni, S. S. and Yadgirwar, P. V. 2004. Comparative Studies on the Biology of *Helicoverpa armigera* on Different Food Substrates. *J. Soils Crops*, **14**:207-208.
  15. Li, Y., Hill, C. B. and Hartman, G. L. 2004. Effect of Three Resistant Soybean Genotypes on the Fecundity, Mortality and Maturation of Soybean Aphid (Homoptera: Aphididae). *J. Econ. Entomol.*, **97**:1106-1111.
  16. Liu, Z., Li, D., Gong, P. Y. and Wu, K. J. 2004. Life Table Studies of the Cotton Bollworm, *Helicoverpa armigera* (Hübner) (Lepidoptera: Noctuidae), on Different Host Plants. *Environ. Entomol.*, **33**:1570-1576.
  17. Maia, A. H. N., Luiz, A. J. B. and Campanhola, C. 2000. Statistical Inference on Associated Fertility Life Table Parameters Using Jackknife Technique: Computational Aspects. *J. Econ. Entomol.*, **93**:511-518.
  18. Meyer, J. S., Ingersoll, C. G., McDonald, L. L. and Boyce, M. S. 1986. Estimating Uncertainty in Population Growth Rates: Jackknife vs. Bootstrap Techniques. *Ecology*, **67**:1156-1166.
  19. Mironidis, G. K. and Savopoulou-Soultani, M. 2008. Development, Survivorship and Reproduction of *Helicoverpa armigera* (Lepidoptera: Noctuidae) under Constant and Alternating Temperatures. *Environ. Entomol.*, **37**:16-28.
  20. Naseri, B., Fathipour, Y., Moharramipour, S. and Hosseininaveh, V. 2009. Comparative Life History and Fecundity of *Helicoverpa armigera* (Lepidoptera: Noctuidae) on Different Soybean Varieties. *Entomol. Sci.*, **12**: 147-154
  21. Razmjou, J., Moharramipour, S., Fathipour, Y. and Mirhoseini, S. Z. 2006. Effect of Cotton Cultivar on Performance of *Aphis gossypii* (Homoptera: Aphididae) in Iran. *J. Econ. Entomol.*, **99**:1820-1825.
  22. Reddy, K. S., Rao, G. R., Rao, P. A. and Rajasekhar, P. 2004. Life Table Studies of the Capitulum Borer, *Helicoverpa armigera* (Hübner) Infesting Sunflower. *J. Entomol. Res.*, **28**:13-18.
  23. Scriber, J. M. and Slansky, F. 1981. The Nutritional Ecology of Immature Insects. *Annu. Rev. Entomol.*, **26**: 183-211.
  24. Singh, A. K. and Mullick, S. 1997. Effect of Leguminous Plants on the Growth and Development of Gram Pod Borer, *Helicoverpa armigera*. *Indian J. Entomol.*, **59**:209-214.
  25. Smith, C. W. 1992. History and Status of Host Plant Resistance in Cotton to Insects in the United States In: "Advances in Agronomy", Sparks, D. L. (Ed). Vol. 48, Academic Press, Sandiego, PP. 251-296.
  26. Taghizadeh, R., Fathipour, Y. and Kamali, K. 2008. Influence of Temperature on Life Table Parameters of *Stethorus gilvifrons* (Mulsant) (Coleoptera: Coccinellidae) Fed on *Tetranychus urticae* Koch. *J. Appl. Entomol.*, **132**: 638-645.
  27. Tsai, J. H. and Wang, J. J. 2001. Effects of Host Plants on Biology and Life Table Parameters of *Aphis spiraecola* (Homoptera: Aphididae). *Environ. Entomol.*, **30**:45-50.
  28. van Lenteren, J. C. and Noldus, L. P. J. J. 1990. Whitefly-plant Relationship: Behavioral and Biological Aspects. In: "Whitefly: Their Bionomics, Pest Status and Management", Gerling, D. (Ed). Intercept, Andover, U. K., PP. 47-89.
  29. van Steenis, M. J. and El-khawass, K. A. M. H. 1995. Life History of *Aphis gossypii* on Cucumber: Influence of Temperature, Host Plant and Parasitism. *Entomol. Exp. Appl.*, **76**: 121-131.
  30. Wilson, F. and Huffaker, C. B. 1976. The Physiology, Scope and Importance of Biological Control. In: "Theory and Practice of Biological Control", Huffaker, C. H. and Messenger, P. S. (Eds). Academic Press, New York, PP. 3-15.
  31. Yu, F. L., Wu, G., Liu, T. J., Zhai, B. P. and Chen, F. J. 2008. Effects of Irrigation on the Performance of Cotton Bollworm, *Helicoverpa armigera* (Hübner) during Different Pupal Stages. *Int. J. Pest Manag.*, **54**(2): 137-142.



## مقایسه پارامترهای تولید مثل (*Helicoverpa armigera* (Hübner) (Lepidoptera: Noctuidae) روی سبزه رقم سویا

ب. ناصری، ی. فتحی پور، س. محرمی پور، و. حسینی نوه

### چکیده

پارامترهای تولید مثل *Helicoverpa armigera* (Hübner) روی ۱۳ رقم سویا شامل M4، M9، M7، Clark، 356، L17، Williams، Zane، Sahar، JK، Gorgan3، BP و DPX در دمای  $25 \pm 1$  درجه سلسیوس، رطوبت نسبی  $65 \pm 5$  درصد و دوره روشنایی ۱۶ ساعت روشنایی و ۸ ساعت تاریکی مقایسه شد. شب پره‌های نر و ماده ظهور یافته *H. armigera* که دوران قبل از بلوغ خود را روی ارقام مختلف سویا سپری کرده بودند به داخل ظرف تخم‌ریزی منتقل شدند و آزمایشات تا زمان مرگ آخرین فرد ماده ادامه یافت. بیشترین نرخ ناخالص باروری روی رقم M4 (۲۲۳۸ تخم) و کمترین مقدار روی رقم Gorgan3 (۴۶۷ تخم) بود. نرخ ناخالص بارآوری روی رقم M7 (۷۸۲ تخم) بیشترین و روی رقم Gorgan3 (۱۴۹ تخم) کمترین مقدار را داشت. نرخ خالص باروری از ۱۹۲ تا ۱۲۷۵ تخم متغیر بود که بیشترین و کمترین مقدار آن به ترتیب روی ارقام M7 و BP به دست آمد. نرخ خالص بارآوری روی رقم M7 (۵۸۶ تخم) بیشترین و روی رقم Sahar (۵۶ تخم) کمترین میزان را دارا بود. تخم‌های گذاشته شده در هر روز توسط هر فرد ماده از ۵۰ تا ۲۸۲ تخم متغیر بود که کمترین و بیشترین مقدار آن به ترتیب روی ارقام Gorgan3 و M4 بود. نتایج نشان داد ارقام M4، M7، L17، Clark، Williams، M9، M7 و Zane به عنوان گیاهان میزبان مناسب برای تولید مثل جمعیت مطالعه شده *H. armigera* بودند. با این حال، سایر ارقام مورد آزمایش مطلوبیت کمتری برای فعالیت تولیدمثلی *H. armigera* داشتند.