

Design, Fabrication and Evaluation of Electric Forage Chopper with Adjustable Helix Angle

M. Jamshidpouya¹, G. Najafi^{1*}, and T. Tavakoli Hashjin¹

ABSTRACT

In this study, we aimed to design and make an electric forage chopper having a cylinder type cutterhead. In recent years, several models of forage chopper have been manufactured but each of these machines has had problems such as type of power supply system, type of cutting mechanism and feeding mechanism, lack of safety, etc. These problems were solved in this study. In the device that was manufactured in this research, feed rolls rotational speed, rotational speed of the cutting cylinder, blades' helix angle and blades' rake angle was adjustable. So, with these capabilities, these variables can be optimized for any kind of forage, and this information can be used to design and construct suitable machines for crushing any kind of forage. Alfalfa was used to test the machine, where its test matrix was determined using Response Surface Methodology (RSM) modeling method. The results showed that, on average, power requirements for chopping alfalfa was decreased from 12.6 to 9.7% by increasing the helix angle from 0° to 10° and from 10° to 20°, respectively. As rotational speed of the cutting cylinder increases from 500 to 800 rpm, the power used for chopping forage increases by about 56 W. In the conducted tests, maximum power requirements for chopping alfalfa was roughly equal to 200W, which was associated with 158.5 rpm feed rolls rotational speed, 800 rpm rotational speed of the cutting cylinder, and helix angle of zero. Contrarily, minimum power requirements for chopping alfalfa was 114W which was related to 158.5 rpm feed rolls rotational speed, 500 rpm rotational speed of the cutting cylinder, and 20° helix angle. Optimizing test results showed that the most suitable values for the feed rolls rotational speed, rotational speed of the cutting cylinder, and helix angle were 150 rpm, 677 rpm, and 9.22°, respectively, provided that power requirements and particle size are minimized and device capacity is maximized.

Keyword: Abaqus, Adjustable Angle Chopper, Electrical drive; Modeling, RSM modeling method.

INTRODUCTION

Forage chopping is very important for livestock intake. Forage intake could restrict nutrition due to bulkiness. One way to mitigate feed bulkiness is to reduce the particle size of bulky feed resources, especially forage ones (Allen, 1996). Forage particle size, as a physical characteristic, has great importance in the dynamic-rumen livestock, as the proper size of forage particles stimulates rumination, increases salivary secretion, neutralizes ruminal volatile fatty acids, improves milk fat, and

prevents digestive disorders such as acidosis (Teimouri *et al.*, 2004). The results of experiments reveal that reducing the particle size of ration leads to an enhancement in production and quality of Holstein cow dairy milk in the middle of lactation period (Khorramdel *et al.*, 2012). Tall forages in fully mixed rations cannot be homogeneously mixed, therefore, their use in a fully mechanized feeding system associates with problems. Increasing particle size stimulates the cattle to reject large particles (Devries *et al.*, 2008). In Iran, in small animal husbandries, manual choppers

¹ Department of Biosystems Engineering, Tarbiat Modares University, Tehran, Islamic Republic of Iran.

* Corresponding author; e-mail: g.najafi@modares.ac.ir



are employed to crush the forage. To use this tool, at least two workers are needed. Hand-held chopper is not only an intolerable and difficult work, but also associates with dangers of cutting worker's hand or fingers. In industrial animal husbandries, large choppers are used for chopping forage. Exploiting these machines is only cost-effective for chopping large quantities of forage, but it is not much economical for small animal husbandries in terms of either initial purchasing costs, or power requirements rate. In recent years, several models of forage chopper such as electric forage chopper (Madadi, 2012), electric grass cutter for dry and wet forage (Mahmoudi Sorkizadeh *et al.*, 2014), and motorcycle chopper for small animal units (Shahi *et al.*, 2014) have been developed. But, unfortunately, each of these machines not only has problems such as type of power supply system, type of cutting mechanism and feeding mechanism, lack of safety, etc., but also no research has been conducted to optimize design variables of these machines, including rotational speed of the cutting cylinder, feeding speed, angles of cutting blades, and so forth.

Therefore, the current study aimed at manufacturing an electric forage chopper in which principles of safety are met, standard

cutting and feeding mechanisms are benefited, and variables related to design of the machine, including rotational speed of the cutting cylinder, rotational speed of feed rollers and the helix angle of blades can be adjusted so that, using a statistical design, the optimal values for these variables can be determined for each forage.

MATERIALS AND METHODS

Figure 1 shows the Main components of the manufactured chopper in this study

Since the machine cutting cylinder length, stationary knife, and chassis width depend on the length of feed rollers, design process of the machine was started from the feed rollers. The length of the feed rollers was considered 400 mm and their diameter of 65 mm and in the center of each roller, a pipe with a diameter of 25 mm was set as the roller axis according to the previous test results that were performed by Shahi *et al.* (2014).

To choose the bearing of the feed rollers, the pressure applied on rollers through input forage was calculated using Equation (1). In this equation, C and m are material constants and for alfalfa $C= 3 \times 10^{-5}$ and $m= 2$, P is pressure in bar, γ_0 is Specific weight in $\frac{\text{kg}}{\text{m}^3}$

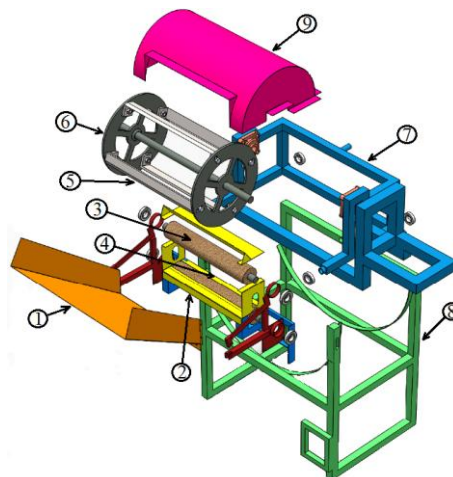

Figure 1. Schematic of the Machine: (1) Input channel, (2) Feed rollers cover, (3) Feed rollers, (4) Stationary knife, (5) knives, (6) Cutting cylinder, (7) Cutting cylinder chassis, (8) Chassis, (9) covering chamber for the cutting cylinder.

and ϵ is strain. The appropriate bearing was selected using Equation (2) and the standard table of SKF Bearings. In this relation C_{10} is catalog load rating, F_D is desired radial load, L_D is desired life, n_D is desired speed in rev min⁻¹, L_R is rating life in hours, n_R is rating speed in rev min⁻¹ and $a=3$ for ball bearings.

$$P = C\gamma_o^m \left[\frac{\epsilon}{1-\epsilon} \right]^m \quad (\text{Tavakoli Hashjin, 2004}) \quad (1)$$

$$C_{10} = F_D \left[\frac{L_D n_D 60}{L_R n_R 60} \right]^{1/a} \quad (\text{Shadravan, 2012}) \quad (2)$$

According to the results of previous tests that were performed by Shahi *et al.* (2014), the diameter of cutting cylinder was set to 300 mm, and, as the length of the feed rollers was 400 mm, the length of cutting cylinder was set to 430 mm. Cutting cylinder had 4 cutting blades, mounted at a 90° angle to each other. The sharpness angle of these blades was considered 35° based on the results of previous tests (Tavakoli Hashjin, 2003). In Figure 2, sharpness angle and helix angle of blade is shown.

Abacus V6.12 software was used to determine the type and belt dimensions suitable for fabricating blades. Chancellor (1987) obtained maximum shear strength of alfalfa in a moisture content of 20% in the range of 7.9 to 16.5 N mm⁻¹ of stationary blade length. If the force applied to the stationary blade unit is 16.5 N mm⁻¹, since the stationary blade length is 400 mm, the force against the blade is 6,600 N. According to Newton's third law, this force is equal to the amount of force being applied on the edge of the cutting blades.

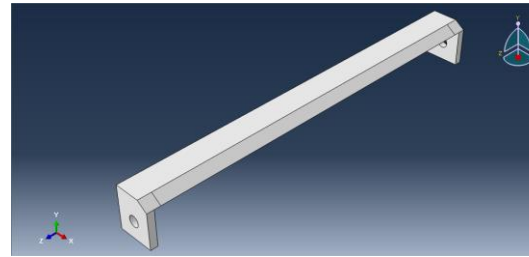

Figure 3. Designed blade in abacus.

Considering the dimensions of the stationary blade as well as the available steel flats in the market, the cutting blade was designed in Abacus V6.12 as shown in Figure 3.

To determine the thickness and width of the steel flats, the designed blade was put under load. The trial and error method was used to determine this dimension. In each test, dimensions of the blade were adjusted as per availability of steel flats in the market, and this trend continued until the maximum Von Mises stress obtained from analyses became less than the steel yield stress. Finally, the steel flat with a size of 40×8 mm was selected to fabricate the blade. In these tests, steels modulus of elasticity, Poisson coefficient and density were considered as 200 Gpa, 0.3, and 7,868.75 kg m⁻³, respectively (Valinejad, 2013). Loading result for the selected steel flat is shown in Figure 4.

The chassis was made up of three main parts as: main chassis, the chassis of cutting cylinder, and the chassis of feed rollers. The height of the main chassis was 700 mm, so that the user could easily feed the forage

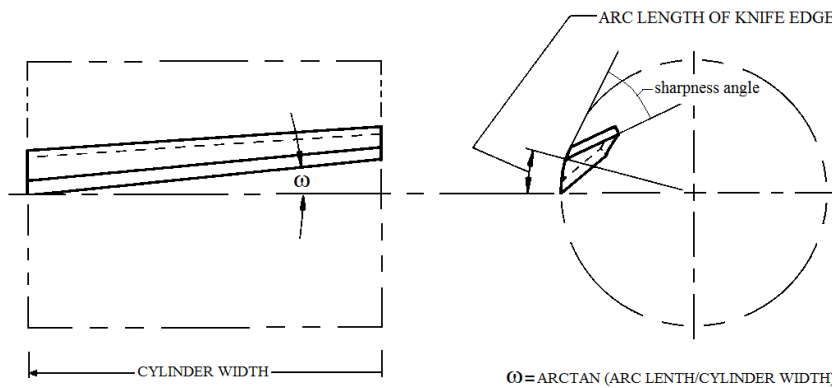

Figure 2. Sharpness and helix angle (ASAE Standards, 1998).

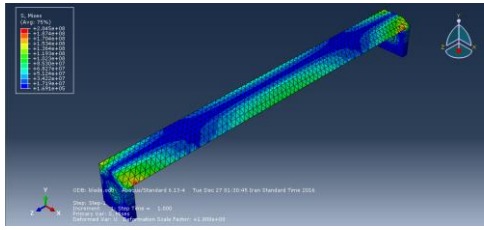

Figure 4. Loaded blade.

inside the machine (Shahi *et al.*, 2014). As regards the dimension of cutting cylinder, in this device height of the main chassis was 700 mm, the width was 640mm and the length was 700 mm. In the front and rear of this section, two arch-shaped rails were mounted. The chassis of the cutting cylinder which was mounted on it, was placed on these rails and connected to the main chassis by a pin. By rotating the cutting cylinder chassis around the pin, the cutting cylinder was angled relative to the stationary knife, through which the helix angle was altered.

In order to change the distance between two feed rollers when varying the thickness of imported material, a system was fabricated to allow the upper roller to move and mounted on the chassis of the feed rollers. In this system, the upper roller is placed under the pressure of a spring and, in addition to compressing the forage prior to being crushed, moves upwards with increasing thickness of the input material. Chain and sprocket wheel were used to transmit the power to the feed system. Using the Equations (3) to (6) and the standard tables (Shadravan, 2012), appropriate chains and sprocket wheels for power transmission from the electromotor to the feed rollers were chosen.

$$D = \frac{P}{\sin(180^\circ/N)} \quad (3)$$

$$H_1 = 0.004N_1^{1.08}n_1^{0.9}p^{(3-0.07p)} \quad (4)$$

$$H_2 = \frac{1000K_r N_1^{1.5} p^{0.8}}{n_1^{1.5}} \quad (5)$$

$$H_{nom} = \min(H_1, H_2) \quad (6)$$

Where, P = Chain Pitch, N = the Number of sprocket teeth, D = Pitch Diameter of the sprocket, H_1 = Nominal power for single-strand chain (link-plate limited), H_2 = Nominal power for single-strand chain

(roller-limited), N_1 = Number of teeth in the smaller sprocket, n_1 = Sprocket speed, rev min^{-1} , p = Pitch of the chain, in, Kr = Constant.

A tightening chain was used in order to loosen and tighten the chain when the upper roller is moved, so that the chain length increases as the roller moves upwards and stretches when the roller is lowered.

If the helix angle of the cutting blades is zero, a straight hardening steel belt can be used as a stationary knife. In the current implement, it is possible to change the angle of the axis of cutting cylinder relative to the stationary knife and, consequently, changing the helix angle. By altering the angle of the cutting cylinder, stationary knife must also be replaced, because by changing the angle of the cutting cylinder the blades on the cylinder are spaced apart from the two stationary knife heads and, as a result, the cutting operation in two stationary knife heads is not properly executed and the input materials are cut only in the center of the stationary knife. To solve this problem, the stationary knife edge must be fabricated in a curved shape (Figure 5). The stationary knife curve equation was obtained as follows. In Equation (7), r is cutting cylinder radius and θ is helix angle.

$$y = r - \sqrt{r^2 - (x \cdot \sin\theta)^2} \quad (7)$$

In order to cover the feed rollers, a chamber made up of galvanized sheet was designed. This sheet is shown in yellow color in Figure 1. As illustrated in the figure,

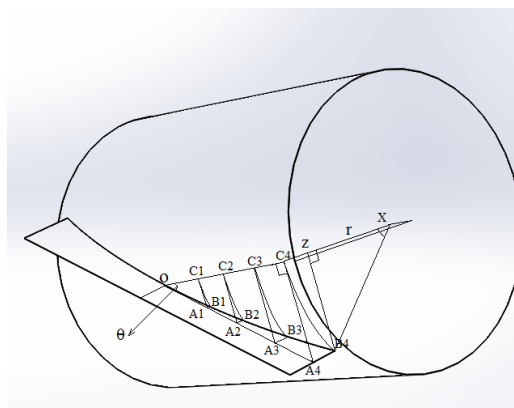

Figure 5. Stationary knife curve.

this section is mounted on the chassis of the feed rollers. The input channel designed for the machine is shown in orange color in Figure 1. In order to slide the forage on the feed channel surface and readily reach the feed rollers, the input channel should be inclined to be fabricated. Therefore, in this device, the slope of channel was computed as 35° according to the friction coefficient of fodder with galvanized sheet (ASAE Standards, 1998). Since the chamber length of feed rollers and its height were set respectively to 410 and 105 mm, the width and height of the feed channel at in situ connection to the machine were set at 410 and 105 mm, respectively. Outer opening dimensions of the feed chamber were set 1.5 times the dimensions of the inner one, so that the feed is carried out easily. Since the length of the alfalfa stems usually ranges between 300 and 900 mm, the length of the feed channel was set to 500 mm. Sheet thickness used in this test was also obtained at 1.5 mm, using Abacus software. To cover the cutting cylinder, a chamber with a radius of 170 mm and a length of 530 mm was designed. In order to cover the side faces of the cutting cylinder chassis, one piece of galvanized sheet was placed on each face equally sizable with the intended one. Also, in the front of the chamber, a rectangular piece with 410 mm length and 105 mm width was cut in order to enter the forage left from the rollers into the main chamber.

In this machine, the power requirements of the cutting cylinder was calculated from Equation (8) and used for supplying its power from a 4-pole electromotor with a power of 2.2kW. In order to control the rotational speed of the cutting cylinder, an EL-series inverter with an output power of 2.2kW was used. In this equation P_T is total power requirement (kW), P_C is power required to chopping forage (kW), P_{air} is power required for air flow (kW), P_{accel} is power required to accelerate chopped forage (kW), P_f is absorbed power due to friction (kW), W is work done during a cut, T_1 is time required for a cut (s), V_K is linear

velocity of blades ($m\ s^{-1}$), M_F is theoretical capacity ($kg\ s^{-1}$), β is average arc from shell which chopped forage move on it (radian), μ is friction coefficient between chopped forage and steel.

$$P_T = P_C + P_{air} + P_{accel} + P_f$$

$$= \frac{W}{T_1} + \frac{V_K^3}{6600} + \frac{M_F V_K^2}{2000} + \frac{\beta \cdot \mu \cdot M_F \cdot V_K^2}{1000}$$

(Minaei, 2001) (8)

The power consumed by feed rollers was calculated from Equation (9) and used to supply the power of the cutting cylinder from a 4-pole electromotor with a power of 0.37kW. To control the rotational speed of the cutting cylinder, an EL model inverter with an output power of 0.37kW was used.

$$P_F = 0.06(P_T + P_F) \text{ (Minaei, 2001) (9)}$$

The power panel map of the machine was plotted using ProfiCAD software, as shown in Figure 6.

In Figure 7, the internal view of the power panel is shown and the final image of the machine is depicted in Figure 8.

Alfalfa was used to test the machine. In this research, a 3-levels-3-factor Box-Behnken design was used to investigate the effect of independent variables on the device power requirements, alfalfa chopping power, particle size percentage < 9 mm and device capacity. Independent variables included the rotational speed of the cutting cylinder, feed rollers rotational speed, and Helix angle of blades. Twelve factorial points were

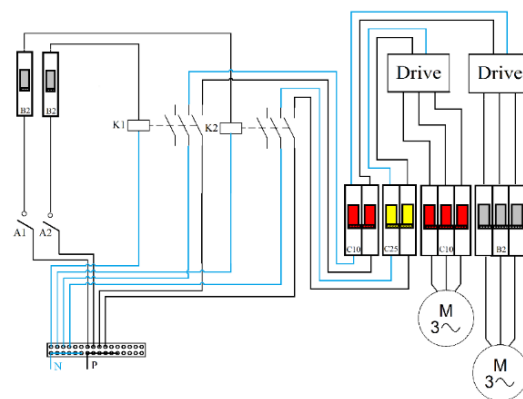

Figure 6. Machine power panel map.

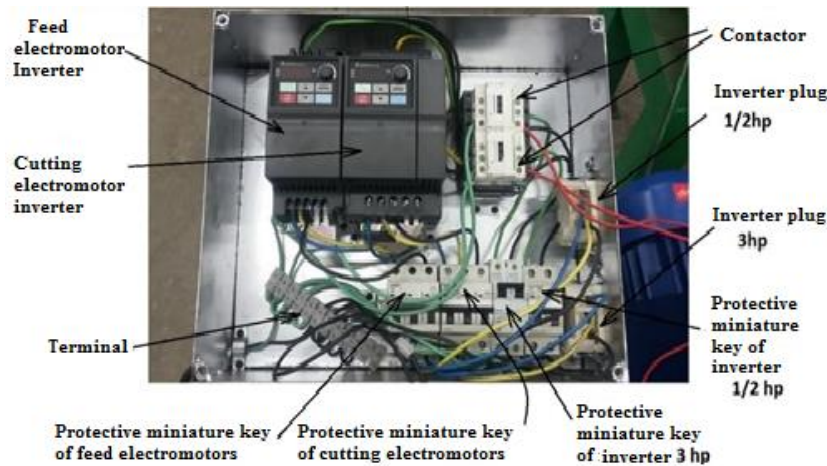

Figure 7. Internal view of the machine's power panel.



Figure 8. Forage chopper after final assembly.

considered for the Box-Behnken factorial design used in this study. Five central points were also considered for fitting a second-order response surface (Hoseini *et al.*, 2018). In Table 1, the test matrix is shown along with the used independent variables. Additionally, the proposed experimental design by the Response Surface Methodology (RSM) method is shown in Table 2. It is noteworthy that Design-Expert®Software software (version 7.0.0) was employed for statistical analysis and

Table 1. Range of ANOVA

Independent variables	Symbols	Levels of each factor		
Feed rollers rotational speed (rpm)	A	132	158.5	185
Rotational speed of cutting cylinder (rpm)	B	500	650	800
Helix angle (°)	C	0	10	20

optimization was performed using the RSM to achieve the highest device capacity and particle size percentage < 9 mm and the lowest alfalfa chopping power and device power requirements.

To implement each of the tests indicated by the software, 1 kg of baler-compressed alfalfa was used with an average moisture content of 20.54%. The compressed alfalfa package was first divided into packs of 1 kg using a digital scale with P8-510DR code with 0.05% accuracy. The result of the experiments showed that decrease in moisture content of stem from 78 to 46% wb led to 16.3 and 16.7% decrease in the shearing strength and specific shearing energy, respectively (Hemmatian *et al.*, 2012) and the shear stress and the shear energy of Safflower Stalk increased with increasing moisture content (Shahbazi *et al.*, 2012). So, in order to maintain the moisture of the forage during the experiments, plastic bags were used to pack the forage (Figure 9).

DW-6060 watt meter of Lutron model

Table 2. Experimental design proposed by RSM.

Random	Run	A	B	C	Device power requirements (W)	Alfalfa chopping power (W)	Particle size percentage < 9 mm (%)	Capacity (kg h ⁻¹)
		Feed rollers rotational speed (rpm)	Rotational speed of cutting cylinder (rpm)	Helix angle (°)				
13	1	158.5	650	10	254	148	64.58	293
6	2	185	650	0	291	178	50.06	355
14	3	158.5	650	10	257	149	62.4	307
16	4	158.5	650	10	261	153	67.52	283
17	5	158.5	650	10	259	146	60.12	289
2	6	185	500	10	254	122	45.36	341
12	7	158.5	800	20	296	158	76.42	295
8	8	185	650	20	288	141	51.46	352
4	9	185	800	10	345	182	66.14	348
3	10	132	800	10	272	181	86.7	239
9	11	158.5	500	0	222	136	45.9	303
10	12	158.5	800	0	309	194	69.7	288
7	13	132	650	20	230	131	75.11	253
5	14	132	650	0	234	182	73.8	244
15	15	158.5	650	10	258	156	69.19	302
1	16	132	500	10	195	119	64.5	254
11	17	158.5	500	20	219	114	47.8	310

with $\pm 1\%$ accuracy was used to measure the power requirements. DT-2268 Lutron revolution meter device with 0.05% accuracy was used to measure and adjust the rotational speed of the feed roll and cutting cylinder. To measure the practical capacity of the machine, the time spent on chopping alfalfa was measured in each test and the device capacity was obtained by dividing the weight of crushed alfalfa into used time. To measure the average length of the chopped forage, a series of sieves similar to Pennsylvania sieves (Penn State Particle Separator), including two sieves and a tray was designed and made. To make the upper

**Figure 9.** Packed alfalfa

and lower sieves, a perforated sheet with hole diameters of, respectively, 19 mm and 9 mm was used (Mertens, 2000). To perform each test, feed rollers rotational speed, speed of cutting cylinder, and helix angle of the blades were adjusted firstly. After recording device power requirements at an idle mode, the forage was fed uniformly to the machine and at the same time with its chopping, it was filmed from the watt meter display screen to prevent any errors of reading the value on the display. In each test, the crushed time of the forage was also measured.

The crushed forages were poured into a plastic bag in each test and well mixed, then, three specimens of 50 g were removed from each bag for each test and screened using the fabricated sieves. The materials remaining on the upper sieve were the ones whose size was more than 19 mm, and particles between 9 and 19 mm stayed on the second sieve. Finally, particles smaller than 9 mm gathered into the tray. Following, the weight of the materials in each of the sieves was measured and their percentage contained in each sieve was recorded.



Due to the fact that the machine's settings were put to produce pieces of up to 19 mm in length, and calculating the length of pieces larger than 19 mm was not possible due to the variable particles length, only the particles remaining inside the tray and on the second sieve were used to compare different tests with each other.

RESULTS AND DISCUSSION

The variance analysis results for device power requirements in the idle mode are reported in Table 3. The results given in the table show that the model was significant for device power requirements in the idle mode and lack of fit was insignificant; therefore, the modeling performed by the software was reliable and it has predicted highly accurate and actual data.

Results of this test implied that the effect of feed rollers rotational speed and speed of cutting cylinder on device power requirements in the idle mode was significant at 1% level. Also, the effect of helix angle of blades, second power of the roller speed, and second power of the cutting cylinder speed on device power requirements in the idle mode was also significant at 5% level. The effectiveness of the speed of cutting cylinder and feed rollers rotational speed on device power

requirements is quite reasonable, because according to the power relation ($P = T \times \omega$) in constant torque, power requirements increases as rotational speed rises. Also, Persson (1987) stated in his research that increasing the speed of blades usually undergoes an increase in power losses, including both losses due to material acceleration or other casualties. Consequently, the total power required for the chopping device increases with increasing the speed of blades, although chopping power remains unchanged.

Equation (10) denotes second-order modified models of device power requirements variations in the idle mode with a determination coefficient of 0.99. In this equation, A is feed rollers rotational speed in (rpm), B is rotational speed of cutting cylinder in (rpm) and C is helix angle in ($^{\circ}$).

$$\text{Device Power} = 257.8 + 30.88A + 41.5B - 2.88C + 4.72B^2 \quad (10)$$

(Figure 10-a) shows average device power requirements variation at different feed rollers rotational speeds. As depicted in the diagram, device power requirements increases by 62.65W, as feed rollers rotational speed increases from 132 to 185 rpm. Because the torque required to rotate the cutting cylinder in idle mode is always constant, with increasing rotational speed,

Table 3. Variance analysis table for device power requirements in the idle mode (statistical significance at P-value= 0.05).

Source	Sum of squares	df	Mean square	F value	P-value (Prob> F)	
Model	21715.07	9	2412.79	225.04	< 0.0001	
A- Feed rollers rotational speed	7626.13	1	7626.13	711.3	< 0.0001	
B- Rotational speed of cutting cylinder	13778	1	13778	9	< 0.0001	
C-helix angle	66.13	1	66.13	6.17	0.042	
AB	49	1	49	4.57	0.0699	
AC	0.25	1	0.25	0.023	0.8829	
BC	25	1	25	2.33	0.1706	
Residual	75.05	7	10.72			
Lack of fit	48.25	3	16.08	2.4	0.2084	Not significant
Pure error	26.8	4	6.7			
		1				
Cor total	21790.12	6				

power consumption increases.

(Figure 10-b) displays average device power requirements at different helix angles. In this diagram, with an increase in the helix angle of blades from zero to 20°, the amount of device power requirements drops by about 6W. Because the cutting cylinder chamber and the cutting cylinder act as a centrifuge pump where in suction port is two heads of the cylinder chamber and discharge port is entry and exit ports of forage. Increasing the helix angle decreases the cross-section of the intake port of forage (one of the discharge ports). Therefore, with increasing helix angles, the air is pumped less and less power is consumed.

(Figure 10-c) shows average device power requirements at different rotational speeds of the cutting cylinder. As illustrated in the diagram, device power requirements increase by as much as 83W by increasing the rotational speed of the cutting cylinder from 500 to 800 rpm. Because in idle mode, the torque needed to rotate the cutting cylinders is constant, the power

requirements increase with increasing rotational speed.

(Figure 10-d), shows the three-dimensional diagram of device power requirements in the idle mode with rotational speed of the cutting cylinder and the feed rollers rotational speed where the helix angle is 10°. As illustrated clearly in the diagram, device power requirement increases as feed rollers rotational speed and rotational speed of the cutting cylinder increase.

The result of the variance analysis of the amount of power needed for forage chopping is shown in Table 4. In this table, the model is still significant and lack of fit is not significant, while satisfying these conditions confirms the validity of modeling done by the software.

The results of this test revealed that the effect of rotational speed of the cutting cylinder and helix angle factors on the amount of power consumed for forage chopping was significant at 1% level and the effect of other factors was insignificant.

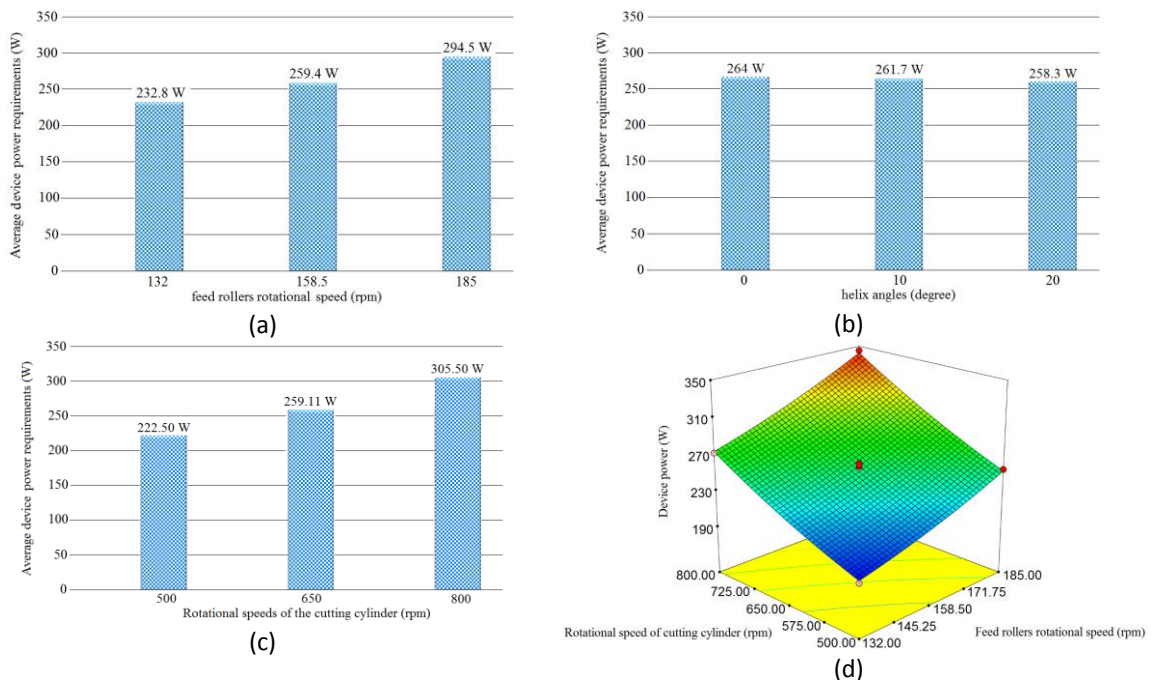

Figure 10. Average device power requirements (a) and feed rollers speed variation., (b) variations at different helix angles (b), (c) variations at different rotational speeds of the cutting cylinder, and (d) Diagram of relationship between device variables with power requirements in the idle mode.



Equation (11) denotes the modified quadratic model of the power variations required for alfalfa chopping with a determination coefficient of 0.95. In this equation, A is feed rollers rotational speed (rpm), B is rotational speed of cutting cylinder (rpm) and C is helix angle ($^{\circ}$).

$$\text{chopping Power} = 150.4 + 1.25A + 28B - 18.25C \quad (11)$$

(Figure 11-a) demonstrates the average forage chopping power variation graph at different feed rollers rotational speed. As shown in the diagram, changing the feed rollers rotational speed does not vary the rate of power consumed. Because the feed rollers only direct the material to the cutting cylinder, they don't have any role in chopping the forage, i.e. the cutting operation is performed only by a cutting cylinder.

In (Figure 11-b), the diagram of average power variation consumed for forage chopping is shown at different helix angles. As it is clear from the figure, the power needed for forage chopping drops from 12.6 to 9.7% as helix angle increases from, respectively, zero to 10° and from 10° to 20° . Because the time required for each cutting is increased, the apparent power requirement for cutting the alfalfa decreases (Shahi et al., 2014).

(Figure 11-c) shows the diagram of average power variation consumed for

forage chopping at different rotational speeds of the cutting cylinder. As shown in this diagram, increasing the rotational speed of the cutting cylinder leads to increasing the power needed for forage chopping. Research results showed that with the increase in shearing speed from 5 to 15 mm min^{-1} , shearing strength and the specific shearing energy increased 3.2 and 4.6%, respectively (Hemmatian et al., 2012)

(Figure 11-d) depicts the three-dimensional diagram of the power variation needed for chopping with rotational speed of the cutting cylinder and helix angle under the circumstances that feed rollers rotational speed is equal to 158.5 rpm. As can be seen in the diagram, increasing the rotational speed of the cutting cylinder gives rise to an increase in the amount of power required, because at constant feed rollers rotational speed, the cut length of the crushed pieces decreases as the rotational speed of the cutting cylinder increases and requires more power requirements. In this diagram, the amount of needed chopping power is reversely related to the helix angle, meaning that it decreases with an increase in the helix angle.

The result of variance analysis for the percentage of particles smaller than 9 mm is shown in Table 5. These results reveal that the model is significant and lack of fit is insignificant. Therefore, the modeling

Table 4. Variance analysis table for the power required to alfalfa chopping.

Source	Sum of squares	df	Mean square	F value	P-value (Prob> F)	
Model	9215.68	9	1023.96	31.41	< 0.0001	Significant
A- Feed rollers rotational speed	12.5	1	12.5	0.38	0.5554	
B- Rotational speed of cutting cylinder	6272	1	6272	192.39	< 0.0001	
C-helix angle	2664.5	1	2664.5	81.73	< 0.0001	
AB	1	1	1	0.031	0.8659	
AC	49	1	49	1.5	0.2598	
BC	49	1	49	1.5	0.2598	
A ²	69.06	1	69.06	2.12	0.1889	
B ²	50.12	1	50.12	1.54	0.255	
C ²	53.06	1	53.06	1.63	0.2427	
Residual	228.2	7	32.6			
Lack of Fit	163	3	54.33	3.33	0.1376	not significant
Pure Error	65.2	4	16.3			
Cor Total	9443.88	16				

Table 5. Variance analysis table for particle size less than 9 mm.

Source	Sum of squares	df	Mean square	F value	P-value (Prob> F)	
Model	2187.99	9	243.11	22.02	0.0002	Significant
A- Feed rollers rotational speed	948.08	1	948.08	85.89	< 0.0001	
B- Rotational speed of cutting cylinder	1137.65	1	1137.65	103.06	< 0.0001	
C-helix angle	16.05	1	16.05	1.45	0.2671	
AB	0.5	1	0.5	0.046	0.8369	
AC	2.03E-03	1	2.03E-03	1.83E-04	0.9896	
BC	5.81	1	5.81	0.53	0.4918	
A ²	13.38	1	13.38	1.21	0.3073	
B ²	3.19	1	3.19	0.29	0.6078	
C ²	65.27	1	65.27	5.91	0.0453	
Residual	77.27	7	11.04			Not significant
Lack of fit	22.9	3	7.63	0.56	0.6684	
Pure error	54.37	4	13.59			
Cor total	2265.26	16				

performed by the software is valid and the model has predicted actual data with high accuracy.

The results of this test exhibited that the effect of rotational speed of the cutting cylinder and feed rollers rotational speed factors upon particle size percentage less than 9 mm was significant at 1% level, while the effect of helix angle on particle size percentage less than 9 mm was not significant. In the equation ($L_F = \frac{6 \times 10^4 V_F}{n_c \cdot Z}$)

L_F is theoretical particle size of chopped forage in mm, V_F is feed speed in m/s, n_c is rotational speed of cutting cylinder in rpm, Z is number of blades and this equation developed by Kepner *et al.* (1978) to calculate the theoretical length of the chopped particles by precise cutting forage choppers, feed roller rotational speed is in the numerator of the equation, consequently, with the increase in the feed rollers rotational speed, the chopped particle size increases, and as a result, the percentage of small particle size decreases which rotational speed of the cutting cylinder at the denominator of this equation. Therefore, chopped particle size decreases as rotational speed of the cutting cylinder increases and the percentage of small particle size increases.

Equation (12) denotes modified quadratic model of the chopped particle size

percentage smaller than 9 mm with a determination coefficient of 0.93. In this equation, A is feed rollers rotational speed in (rpm), B is rotational speed of cutting cylinder (rpm) and C is helix angle ($^{\circ}$).

$$\text{chopping Power} = 63.34 - 10.89A + 11.93B + 1.42C \quad (12)$$

(Figure 12-a) shows the variation of average particle size percentage smaller than 9 mm at different feed rollers rotational speeds. As shown in this diagram, the percentage of particle size smaller than 9 mm is reduced by 21.77% as the feed rollers rotational speed increases from 132 to 185 rpm. Since by increasing the rotational speed of the feed rollers the length of the crushed pieces increases, the particle size percentage smaller than 9 mm decreases.

(Figure 12-b) shows the variation of average particle size percentage smaller than 9 mm at different helix angles. As this figure shows, there is no significant relationship between the variations of helix angle values with particle size percentage smaller than 9 mm.

(Figure 12-c) shows the diagram of average particle size percentage variation smaller than 9 mm at different rotational speeds of the cutting cylinder. As shown in this figure, with the increase in the rotational speed of the cutting cylinder from 500 to 800 rpm, the percentage of particle size smaller than 9 mm increases by 23.85%.

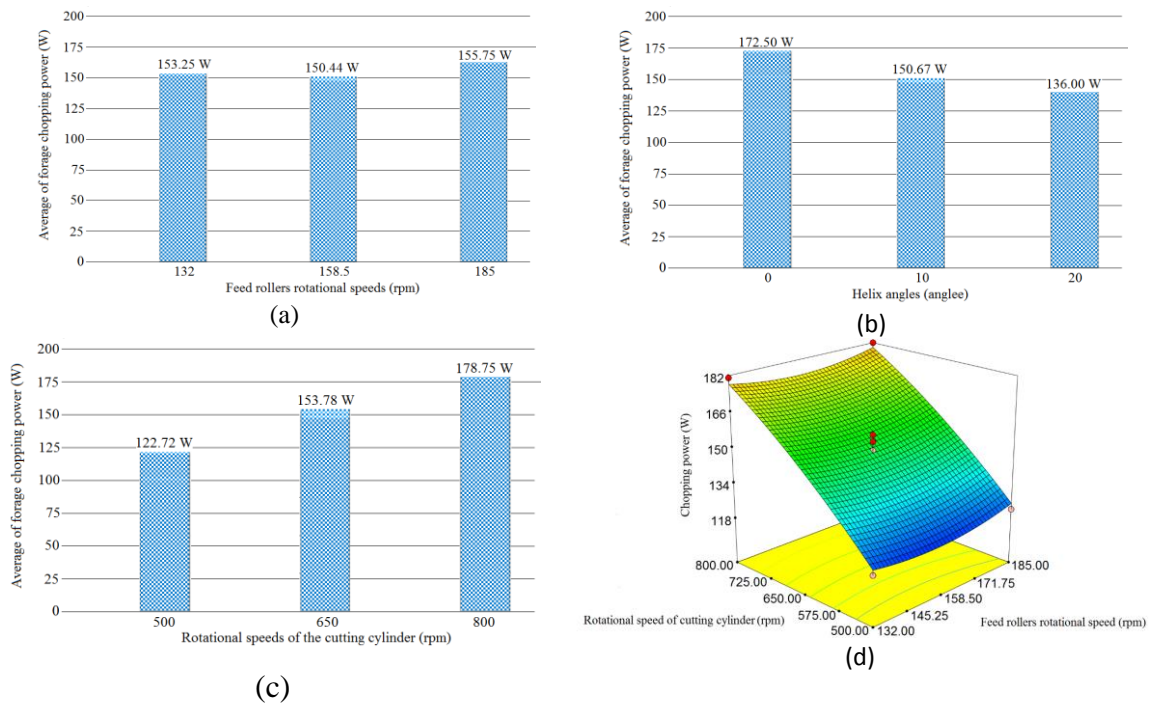

Figure 11. Average power requirements (a) variation graph for forage chopping at different feed rollers rotational speeds, (b) diagram consumed for forage chopping at different helix angles, (c) diagram for chopping at different rotational speeds of the cutting cylinder, and (d) Chopping power with rotational speed of the cutting cylinder and helix angle variation diagram.

Since with increasing the rotational speed of the cutting cylinder the number of cuts per unit time increases, the length of the crushed particles is shorter and the amount of particle size percentage smaller than 9 mm increases.

(Figure 12-d) shows a three-dimensional diagram associated with the percentage of smaller than 9 mm chopped particle size variations with rotational speed of the cutting cylinder and feed rollers rotational speed at 10-degree helix angle. As illustrated in the diagram, the percentage of chopped particle size smaller than 9 mm is related reversely to the rotational speed of the cutting cylinder and directly to the feed rollers rotational speed.

The result of variance analysis for device capacity is shown in Table 6.

As expected, the results of variance analysis revealed that the effect of rotational speed of the cutting cylinder and helix angle variables on the device capacity was not

significant and the only significant factor was the feed roll velocity at 1% level.

Equation (13) denotes the modified quadratic model for device capacity changes with a determination coefficient of 0.98. In this equation A is feed rollers rotational speed (rpm), B is rotational speed of cutting cylinder (rpm) and C is helix angle (°).

$$\text{Capacity} = 294.41 + 50.75A - 4.75B + 2.5C \quad (13)$$

In the equation ($M_F = \frac{\rho_F \cdot A_T \cdot V_F}{6 \times 10^4}$) introduced by Minaei in 2001 to calculate the theoretical capacity of forage chopping machines, feed rollers rotational speed in the equation numerator was the sole factor affecting the device capacity. According to this, the device capacity rises as the feed rollers rotational speed increases.

(Figure 13-a) shows the variation of the average device capacity at a different feed rollers rotational speeds. According to this figure, as the feed rollers rotational speed goes from 132 to 185 rpm, the device capacity increases by 101.5 kg h⁻¹.

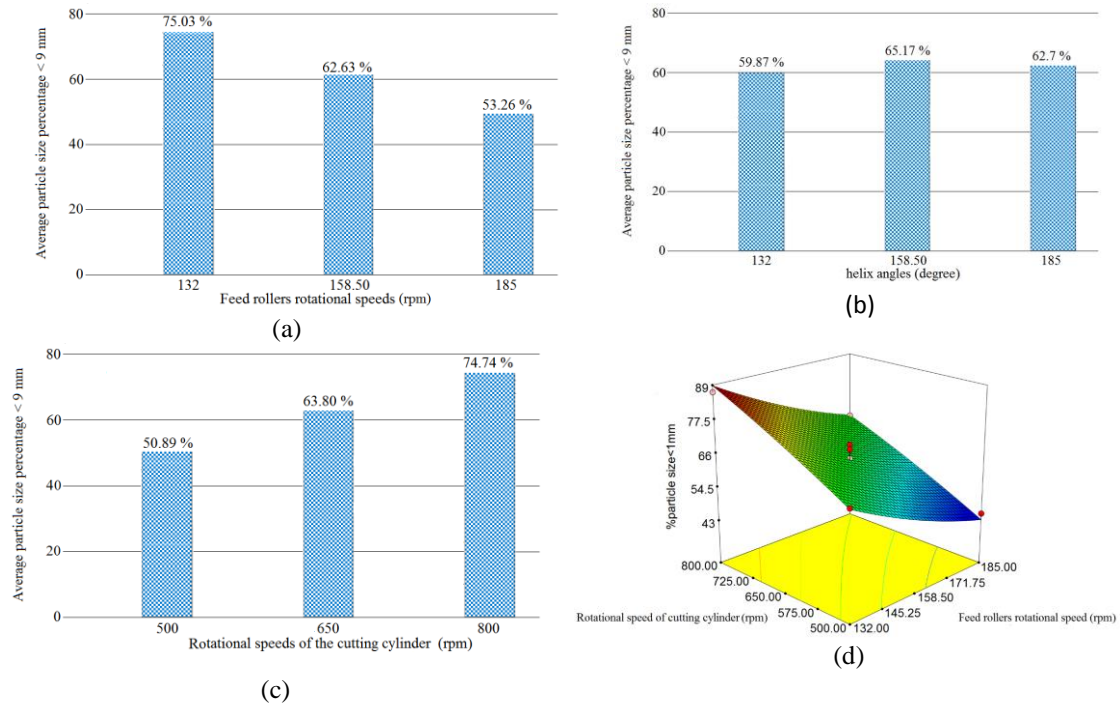

Figure 12. Variation of average particle size percentage < 9 mm at (a) different feed rollers rotational speeds. (b) at different helix angles. (c) at different rotational speeds of the cutting cylinder. (d) Variation of chopped particle size percentage < 9 mm with rotational speed of the cutting cylinder and feed rollers rotational speed.

Table 6. Variance analysis table for the device capacity.

Source	Sum of squares	df	Mean square	F value	P-value (Prob> F)	
Model	21102.32	9	2344.7	34.94	< 0.0001	Significant
A- Feed rollers rotational speed	20604.5	1	20604.5	307.01	< 0.0001	
B- Rotational speed of cutting cylinder	180.5	1	180.5	2.69	0.145	
C-helix angle	50	1	50	0.74	0.4167	
AB	121	1	121	1.8	0.2213	
AC	36	1	36	0.54	0.4877	
BC	0	1	0	0	1	
A^2	7.67	1	7.67	0.11	0.7452	
B^2	1.78	1	1.78	0.027	0.8753	
C^2	99.04	1	99.04	1.48	0.2638	
Residual	469.8	7	67.11			
Lack of fit	93	3	31	0.33	0.806	Not significant
Pure error	376.8	4	94.2			
Cor total	21572.12	16				

(Figure 13-b) shows the diagram of device average capacity variation at different helix angles. As shown in this diagram, the device capacity remains almost constant as the helix angle increases.

(Figure 13-c) depicts device average capacity variation at different rotational speeds of the

cutting cylinder. Based on this figure, with the increase in the rotational speed of the cutting cylinder, device capacity remains almost constant.

(Figure 13-d) displays the three-dimensional diagram of the device capacity changes with the feed rollers rotational speed and rotational speed



of the cutting cylinder. As the figure illustrates, the device capacity is directly related to the feed rollers rotational speed.

To find the optimal point of the test variables, optimization process was performed with the condition of either minimizing the device power requirements and chopping power, or

maximizing the device capacity and particle size percentage smaller than 9 mm. Since the percentage of chopped particle size was more important than the other ones, in the process of optimization, the percentage of chopped particle size was weighed to 3 and, finally, the following point was presented as the optimum point by the

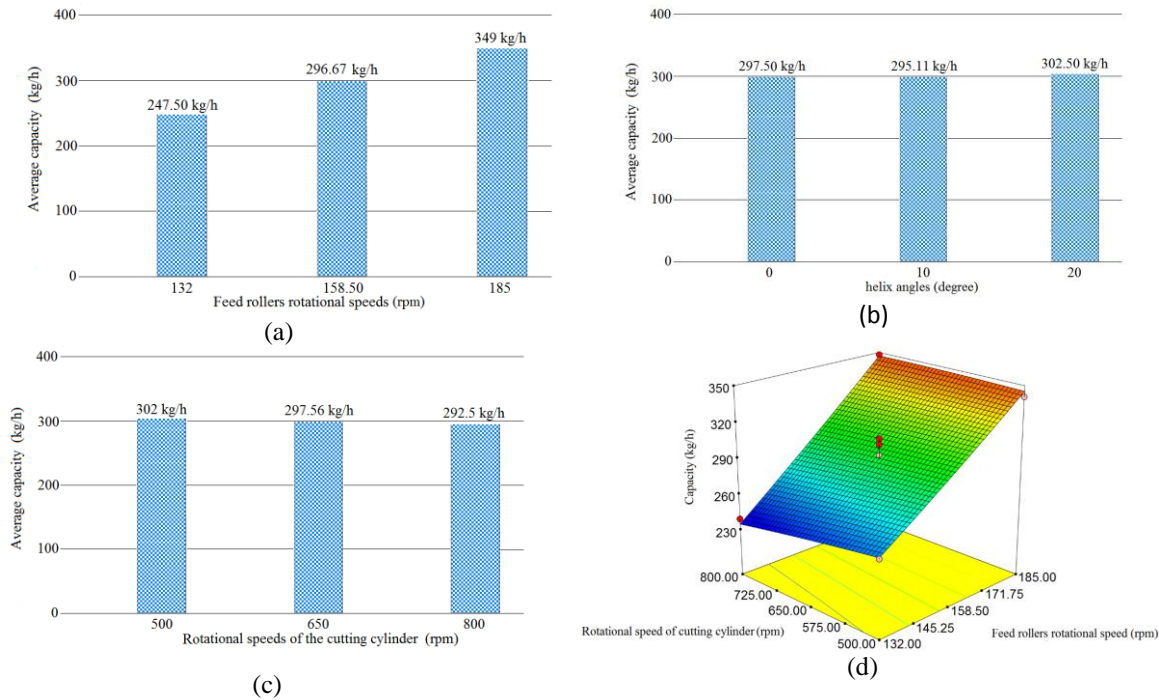

Figure 13. Diagram of device average capacity at (a) different feed rollers rotational speeds (b) at different helix angles, (c) at different rotational speeds of the cutting cylinder, and (d) Diagram of the device capacity variation with rotational speed of the cutting cylinder and feed rollers rotational speed.

Table 7. The optimal point provided by the software.

	Feed rollers rotational speed (rpm)	Rotational speed of the cutting cylinder (rpm)	Helix angle (°)	Device power (W)	Chopping power (W)	%Particle size < 9mm (%)	Capacity (kg h ⁻¹)
1	149.77	677.3	9.22	256.879	158.461	70.416	279.633

Table 8. The device test results at optimal point.

	Device power (W)	%E	Chopping power (W)	%E	%Particle size < 9mm (%)	%E	Capacity (kg h ⁻¹)	%E
	256.879		158.461		70.416		279.633	
1	259	0.8	146	7.9	64.57	8.3	254.7	8.9
2	264	2.8	152	4.1	67.82	3.7	263.9	5.6
3	265	3.2	149	6.0	65.19	7.4	269.8	3.5

software (Table 7).

As given in Table 7, the difference of the derived values with the predicted value was less than 10%, therefore, the resulting modeling was valid.

CONCLUSIONS

The results showed that, on average, power requirements for chopping alfalfa decreased from 12.6 to 9.7% by increasing the helix angle from 0° to 10° and from 10° to 20°, respectively. In the case where the distance between the blade and stationary knife was greater than 4 mm and the linear speed of cutting blades was less than 4 m s⁻¹, the decrease in the helix angle increased average size of the chopped particles. By increasing the rotational speed of the cutting cylinder from 500 to 800 rpm, the power requirements for chopping forage increased by approximately 56 Watts. In the conducted tests, the maximum power requirements for chopping alfalfa was related to the feed rollers rotational speed of 158.5 rpm, the rotational speed of the cutting cylinder of 800 rpm, and the helix angle of zero, which was approximately equal to 200W. This result indicates that the value provided by Chancelleor (1987) is incorrect for alfalfa maximum chopping power, while the value obtained by Shahi *et al.* (2014) is much closer to reality. In these tests, the lowest power requirements for alfalfa chopping was achieved at 114W for the feed rollers rotational speed of 158.5 rpm, the rotational speed of the cutting cylinder of 500 rpm, and the helix angle of 20°. The device capacity was directly related to the feed rollers rotational speed, and had no relation to the helix angle and rotational speed of the cutting cylinder. The size of the chopped particles was directly related to the feed rollers rotational speed, whereas it had a reverse relationship with the rotational speed of the cutting cylinder.

REFERENCES

- Allen, M. S. 1996. Physical Constraints on Voluntary Intake of Forage by Ruminants. *J. Anim. Sci.*, **74**: 3063-3075.
- ASAE Standard. 1998. D251.1. Friction Coefficients of Chopped Forages.
- ASAE Standard. 1998. S472. Terminology for Forage Harvesters and Forage Harvesting.
- Chancelleor, W. J. 1987. *Cutting of Biological Material*. Agricultural Engineering Hand Book, (Ed.): Brown, R. CRC Press Inc.
- Devries, T. J., Dohme, F. and Beauchemin, K. A. 2008. Repeated Ruminant Acidosis Challenges in Lactating Dairy Cows at High and Low Risk for Developing Acidosis: Feed Sorting. *J. Dairy Sci.*, **91**: 3958–3967.
- Hemmatian, R. Najafi, G. Hosseinzadeh, B. Tavakoli Hashjin, T. Khoshtaghaza, M. H. 2012. Experimental and Theoretical Investigation of the Effects of Moisture Content and Internodes Position on Shearing Characteristics of Sugar Cane Stems. *J. Agr. Sci. Tech.*, **14**: 963-974.
- Hoseini, s.s. Najafi, G. Ghobadian, B. Mamat, R. Ebadi, M. T. Talal Yusaf. 2018. *Ailanthus altissima* (Tree of Heaven) Seed Oil: Characterisation and Optimization of Ultrasonication-Assisted Biodiesel Production. *J. Fuel*, **220**: 621-630
- Kepner, R. A., Bainer, R. and Brager, E. L. 1978. *Principal of Farm Machinery*. Third Edition, Westport Connecticut, USA.
- Khorramdel, Y. Pir Mohammadi, R. Farhumand, P. and Sahraei Bloordy, M. 2012. Effect of Alfalfa Particle Size on Feed Consumption, Chewing Behavior and Performance of Holstein Cows at Mid-Lactation. *J. Anim. Sci.*, **102**: 122-129.
- Madadi, Q. 2012. *Electric Grinders*. Official Gazette, List of Ads, Patents: 74628.
- Mahmoudi Sorkizadeh, M. and Mahmoudi Sorkizadeh, H. 2014. Electro-Mutated Grinder for Dry and Wet Fodder. Official Gazette of the Country, Patent P., Patent Number: 84511.
- Mertens, D. R. 2000. Physically Effective NDF and Its Use in Dairy Rations Explorids. Feedstuffs, PP. 11-14.
- Minaei, S. 2001. *Agricultural Machinery Design*. Undergraduate Journal of Agricultural Machinery Mechanics, Tarbiat Modarres University.
- Persson, S. 1987. *Mechanics of Cutting Plant Material*. St. Joseph. Michigan USA.
- Shadravan, O. 2012. *Mechanical Engineering Design*. Translation, Norpardazan Publisher.
- Shahbazi, F. and Nazari Galedar, M. 2012. Bending and Shearing Properties of Safflower Stalk. *J. Agr. Sci. Tech.*, **14**: 743-754



17. Shahi, T. and Galychi, A. 2014. *Motorcycle Chopper for Small Animal Units*. Official Country Newspaper, List of Ads, Patent Number: 82112.
18. Tavakoli Hashjin, T. 2003. *Mechanics of Agricultural Products*. Translation, Salakan Publishing.
19. Teimouri Yansari, A. Valizadeh, R. Naserian, A. Christensen, D. A. Yu, P. and Eftekhari Shahroodi, F. 2004. Effect of Alfalfa Particle Size and Specific Gravity on Chewing Activity, Digest-Ability, and Performance of Holstein Dairy Cows. *J. Dairy Sci.*, **87**: 3912-3924.
20. Valinejad, A. 2013. *Steel Key Tables and Standards*. Translation, Designer Publishing.

طراحی، ساخت و ارزیابی علوفه خردکن برقی، با قابلیت تغییر زاویه ماریچ تیغه‌های برش

م. جمشیدپویا، غ. نجفی، ت. توکلی هاشجین

چکیده

در این تحقیق یک دستگاه علوفه خردکن برقی با مکانیزم برش استوانه‌ای ساخته شد. در سال‌های اخیر، چند مدل علوفه خردکن تولید شده است اما هر یک از این ماشین‌ها دارای مشکلات مانند نوع سیستم تغذیه، نوع مکانیسم برش و مکانیسم تغذیه، فقدان امنیت و غیره می‌باشند که این مشکلات در این تحقیق بر طرف شده‌اند. در این دستگاه ساخته شده در این تحقیق سرعت غلتک‌های تغذیه، سرعت استوانه‌ای برش، زاویه ماریچ تیغه‌ها و زاویه خلاصی تیغه‌ها قابل تنظیم می‌باشند. بنابراین با وجود این قابلیت‌ها می‌توان برای هر نوع علوفه مقادیر بهینه‌ی این متغیرها را به دست آورد و از این اطلاعات به منظور طراحی و ساخت دستگاه‌های مناسب برای خرد کردن هر نوع علوفه استفاده نمود. برای آزمایش دستگاه از گیاه یونجه استفاده شد و ماتریس آزمایش دستگاه با استفاده از روش مدل سازی RSM تعیین شد. نتایج آزمایش‌ها نشان داد که به طور میانگین توان برشی با افزایش زاویه ماریچ از صفر تا ۱۰ درجه به میزان ۱۲/۶٪ و از ۱۰ تا ۲۰ درجه به میزان ۹/۷٪ کاهش پیدا می‌کند. با افزایش سرعت استوانه‌ای برش از ۵۰۰ rpm تا ۸۰۰ rpm توان مصرفی برای خرد کردن علوفه تقریباً ۵۶ W افزایش پیدا کرد. در آزمون‌های انجام شده بیشترین توان مصرفی برای خرد کردن یونجه مربوط به سرعت تغذیه‌ی ۱۵۸/۵ rpm، سرعت استوانه‌ای برش ۸۰۰ rpm و زاویه ماریچ صفر درجه بود که تقریباً برابر با ۲۰۰ W به دست آمد و کمترین توان مصرفی برای خرد کردن یونجه مربوط به سرعت تغذیه‌ی ۱۵۸/۵ rpm، سرعت استوانه‌ای برش ۵۰۰ rpm و زاویه ماریچ ۲۰ درجه بود که برابر با ۱۱۴ W وات به دست آمد. بهینه‌سازی نتایج به دست آمده از آزمایش دستگاه نشان داد که مناسب‌ترین مقادیر برای سرعت غلتک‌های تغذیه، سرعت استوانه‌ای برش و زاویه ماریچ با شرط کمینه شدن توان مصرفی و اندازه‌ی ذرات و بیشینه شدن ظرفیت دستگاه به ترتیب برابر با ۱۵۰ rpm، ۶۷۷ rpm و ۹/۲۲ درجه می‌باشند.