

Application of Adaptive Neuro-Fuzzy Inference System (ANFIS) in Forecasting Agricultural Products Export Revenues (Case of Iran's Agriculture Sector)

S. A. Mohaddes¹, and S. M. Fahimifard^{2*}

ABSTRACT

In this study, application of Adaptive Neuro-Fuzzy Inference System (ANFIS) in forecasting three perspectives (1, 2, and 4 years) ahead of Iran's agricultural products export was compared with ARIMA as the most common econometrics linear forecasting method. For this purpose, Iran's agricultural products export revenues related to 1959-2010, and forecast performance measures such as R^2 , MAD, and RMSE were used. Results of the models performance evaluation showed that the forecasted test data related to ANFIS designed architects had more correspondence with the real data in comparison with that of ARIMA forecasted out of sample data. Therefore, the non-linear ANFIS model outperformed the linear ARIMA model for all of the considered perspectives.

Keywords: ANFIS, ARIMA, Non-linear.

INTRODUCTION

The economy of the Islamic Republic of Iran continues to depend heavily on exports of crude oil, petroleum products, and natural gas for the bulk of its foreign exchange earnings. Although the relative share of export revenues accounted for by these hydrocarbons has declined gradually since the early 1980s, it still remains extremely high. This over-dependence on oil and gas exports has rendered the country's economy highly vulnerable to fluctuations in international energy prices and has imposed a severe constraint on the government. Also, there are some 21 councils, bureaus, agencies, banks, and government departments dealing with promotion of non-oil exports, but their efforts have borne only modest results (CBI statistical year books, 2005-2010). According to Central Bank of Iran (2010), the average share of Iran's

agricultural product export in non-oil export revenues was 61.6% during 1973-2010. Iran's non-oil and especially agricultural products export revenues have more steadfastness in comparison with oil and gas export revenues. Since 1979, commercial farming has replaced subsistence farming as the dominant mode of agricultural production. Agricultural exports stood at \$1.2 billion in 2004-2005 and \$2.6 billion in 2007-2008. Major agricultural exports include fresh and dried fruits, nuts, animal hides, processed foods, and spices. Pistachio, raisins, dates, and saffron are the first four export products, from the viewpoint of value. Close to 8 million tons of agricultural products are exported annually (2008). But, according to the Central Bank of Iran, only 3.2 million tons of "agricultural products" were exported in 2008 with a total value of \$3.2 billion, "which showed a 6.1 percent increase over

¹ Agriculture and Natural Resources Research Center of Khorasan Razavi, Mashhad, Islamic Republic of Iran.

² Khorasan Razavi Chamber of Commerce, Industry, Mines and Agriculture, Mashhad, Islamic Republic of Iran.

* Corresponding author, email: mfahimifard@gmail.com



the previous year" (Iran Agribusiness Report, 2010).

Indeed, assessing the punctual methods to forecast Iran's agricultural products export and consequently better planning of export trend and direction in the future is inevitable. In the last few decades, many forecasting models have been developed; among them, the autoregressive integrated moving average (ARIMA) model has been widely used and successfully applied not only in economic time series forecasting, but also as a promising tool for modeling the empirical dependencies between successive times and failures (Ho and Xie, 1998). Recently, it is well documented that many economic time series observations are non-linear while a linear correlation structure is assumed among the time series values. Therefore, the ARIMA model cannot capture nonlinear patterns and approximation of linear models to complex real-world problem is not always satisfactory. While nonparametric nonlinear models estimated by various methods such as Artificial Intelligence (AI) can fit a data base much better than linear models, it has been observed that linear models often forecast poorly, which limits their appeal in applied setting (Racine, 2001). Artificial Intelligence (AI) systems are widely accepted as a technology offering an alternative way to tackle complex and ill-defined problems (Kalogirou, 2003). They can learn from examples, are fault tolerant in the sense that they are able to handle noisy and incomplete data, are able to deal with non-linear problems, and, once trained, can perform prediction and generalization at high speed (Kamwa *et al.*, 1996). They have been used in diverse applications in control, robotics, pattern recognition, forecasting, medicine, power systems, manufacturing, optimization, signal processing, and social/psychological sciences. AI systems comprise areas like expert systems, Artificial Neural Network (ANN), genetic algorithms, fuzzy logic and various hybrid systems, which combine two or more techniques (Kamwa *et al.*, 1996).

Concerning the application of neural nets to time series forecasting, there have been mixed reviews. For instance, Wu (1995) conducted a comparative study between neural networks and ARIMA models in forecasting the Taiwan/US dollar exchange rate. His findings show that neural networks produce significantly better results than the best ARIMA models in both one-step-ahead and six-step-ahead forecasting. Similarly, Hann and Steurer (1996), Zhang and Hu (1998) find results in favor of neural network. Gencay (1999) compared the performance of neural network with those of random walk and Generalized Auto-Regressive Conditional Heteroskedastic (GARCH) models in forecasting daily spot exchange rates for the British Pound, Deutsche Mark, French Franc, Japanese Yen, and the Swiss Franc. He found that forecasts generated by neural network were superior to those of random walk and GARCH models. Ince and Trafalis (2005) proposed a two stages forecasting model which incorporates parametric techniques such as Auto-Regressive Integrated Moving Average (ARIMA), Vector Auto-Regressive (VAR) and co-integration techniques and nonparametric techniques such as Support Vector Regression (SVR) and Artificial Neural Networks for exchange rate prediction. Comparison of these models showed that input selection was very important. Furthermore, findings showed that the SVR outperformed the ANN for the two input selection methods. Haofei *et al.* (2007) introduced a Multi-Stage Optimization Approach (MSOA) used in back-propagation algorithm for training neural network to forecast the Chinese food grain price. Their empirical results showed that MSOA overcomes the weakness of conventional BP algorithm to some extent. Furthermore the neural network based on MSOA can improve the forecasting performance significantly in terms of the error and directional evaluation measurements. Fahimifard (2008) compared the Adaptive Neuro Fuzzy Inference System (ANFIS) and ANN as the nonlinear models

with the ARIMA and GARCH as the linear models to Iran's meat, rice, poultry, and egg retail price forecasting. His research stated that nonlinear models overcome the linear models strongly. Fahimifard *et al.* (2009) studied the application of ANFIS in Iran's poultry retail price forecasting in contrast with ARIMA model. Their findings stated that ANFIS outperformed the ARIMA model in all three 1, 2 and 4 weeks ahead.

According to usefulness of AI models in time series forecasting and importance of non-oil export development in Iran, this study applied the ANFIS in forecasting the three perspectives (1, 2, and 4 years) ahead of Iran's agricultural products export and compared its application with ARIMA as the most common econometrics linear forecasting method.

MATERIALS AND METHODS

In this study, ARIMA and ANFIS models were used and compared for forecasting. Both models are described in this section.

Auto-Regressive Integrated Moving Average (ARIMA) Model

Introduced by Box and Jenkins (1970), in the last few decades, the ARIMA model has been one of the most popular approaches of linear time series forecasting methods. An ARIMA process is a mathematical model used for forecasting. One of the attractive features of the Box-Jenkins approach to forecasting is that ARIMA processes are a very rich class of possible models and it is usually possible to find a process which provides an adequate description to the data. The original Box-Jenkins modeling procedure involved an iterative three-stage process of model selection, parameter estimation, and model checking. Recent explanations of the process (Makridakis *et al.*, 1998) often add a preliminary stage of

data preparation and a final stage of model application (or forecasting).

Also, the ARIMA (p, d, q) model for variable x is as follows:

$$y_t = f(t) + \phi_1 y_{t-1} + \dots + \phi_p y_{t-p} + e_t + \theta_1 e_{t-1} + \dots + \theta_q e_{t-q} \quad (1)$$

Where, y is estimated by the following equation:

$$y_t = \Delta^d x_t = (1-L)^d x_t \quad (2)$$

Where, y_t and e_t are the target value and random error at time t , respectively, $\phi_i (i = 1, 2, \dots, p)$ and $\theta_j (j = 1, 2, \dots, q)$ are model parameters, p and q are integers and often referred to as orders of autoregressive and moving average polynomials, and L and d refer to lag number and orders of integration.

Adaptive Neuro-Fuzzy Inference System (ANFIS)

The ANFIS represents a useful neural network approach for the solution of function approximation problems. In this study, ANFIS has been utilized to forecast Iran's non-oil export. The ANFIS is a multilayer feed-forward network which uses neural network learning algorithms and fuzzy reasoning to map inputs into an output. Indeed, it is a fuzzy inference system (FIS) implemented in the framework of adaptive neural networks. For simplicity, a typical ANFIS architecture with only two inputs leading to four rules and one output for the first order Sugeno fuzzy model is expressed (Wang and Elhag, 2008; Sugeno, 1985). It is also assumed that each input has two associated membership functions (MFs). It is evident that this architecture can be easily generalized to our preferred dimensions. For a first-order Sugeno fuzzy model, a typical rule set with four fuzzy if-then rules can be expressed as (Sugeno, 1985):



- Rule 1: if In_1 is A_1 and In_2 is B_1 then $f_{11} = p_{11}In_1 + q_{11}In_2 + r_{11}$
- Rule 2: if In_1 is A_1 and In_2 is B_2 then $f_{12} = p_{12}In_1 + q_{12}In_2 + r_{12}$
- Rule 3: if In_1 is A_2 and In_2 is B_1 then $f_{21} = p_{21}In_1 + q_{21}In_2 + r_{21}$
- Rule 4: if In_1 is A_2 and In_2 is B_2 then $f_{22} = p_{22}In_1 + q_{22}In_2 + r_{22}$

Where, A_1, A_2, B_1 and B_2 are labels for representing membership functions for the inputs In_1 and In_2 , respectively. Also, p_{ij}, q_{ij} and r_{ij} ($i, j = 1, 2$) are parameters of the output membership functions.

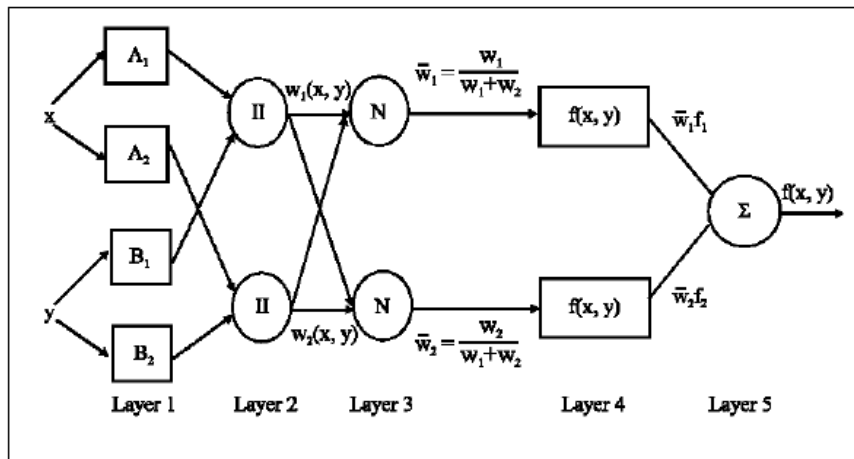

Figure 1. Schematic diagram of ANFIS model.

As can be seen from Figure 1, the architecture of a typical ANFIS consists of five layers, which perform different actions in the ANFIS and are detailed below:

Layer 1: All the nodes in this layer are adaptive nodes. They generate membership grades of the inputs. The outputs of this layer are given by:

$$\begin{aligned} O_{A_i}^1 &= \mu_{A_i}(In_1) \quad , \quad i = 1, 2 \\ O_{B_j}^1 &= \mu_{B_j}(In_2) \quad , \quad j = 1, 2 \end{aligned} \tag{3}$$

Where, In_1 and In_2 are inputs and A_i and B_j are stood for appropriate MFs, which can be triangular, trapezoidal, Gaussian functions or other shapes. In the current study, the Gaussian MFs defined below is utilized:

$$\begin{aligned} \mu_{A_i}(In_1, \sigma_i, c_i) &= \exp\left(-\frac{(In_1 - c_i)^2}{2\sigma_i^2}\right) \quad , \quad i = 1, 2 \\ \mu_{B_j}(In_2, \sigma_j, c_j) &= \exp\left(-\frac{(In_2 - c_j)^2}{2\sigma_j^2}\right) \quad , \quad j = 1, 2 \end{aligned} \tag{4}$$

Where, $\{\sigma_i, c_i\}$ and $\{\sigma_j, c_j\}$ are the parameters of the MFs, governing the Gaussian functions. The parameters in this layer are usually referred to as premise parameters.

Layer 2: The nodes in this layer are fixed nodes labeled Π indicating that they perform as a simple multiplier. The outputs of this layer are represented as:

$$O_{ij}^2 = W_{ij} = \mu_{A_i}(In_1) \mu_{B_j}(In_2) \quad , \quad i, j = 1, 2 \tag{5}$$

Layer 3: The nodes in this layer are also fixed nodes labeled N , indicating that they play a normalization role in the network. The outputs of this layer can be represented as:

$$O_{ij}^3 = \bar{W}_{ij} = \frac{W_{ij}}{\sum_{i=1}^2 \sum_{j=1}^2 W_{ij}} \quad , \quad i, j = 1, 2 \tag{6}$$

which are called normalized firing strengths.

Layer 4: Each node in this layer is an adaptive node, whose output is simply the

product of the normalized firing strength and a first-order polynomial (for a first order Sugeno model). Thus, the outputs of this layer are given by:

$$O_{ij}^4 = \bar{W}_{ij} f_{ij} = \bar{W}_{ij} (p_{ij} In_1 + q_{ij} In_2 + r_{ij}) \quad ,$$

$$i, j = 1, 2 \quad (7)$$

Parameters in this layer are referred to as consequent parameters.

Layer 5: The single node in this layer is a fixed node labeled Σ , which computes the overall output as the summation of all incoming signals, i.e.

$$Out = O^5 = \sum_{i=1}^2 \sum_{j=1}^2 \bar{W}_{ij} f_{ij} =$$

$$\sum_{i=1}^2 \sum_{j=1}^2 \bar{W}_{ij} (p_{ij} In_1 + q_{ij} In_2 + r_{ij}) =$$

$$\sum_{i=1}^2 \sum_{j=1}^2 [(\bar{W}_{ij} p_{ij}) In_1 + (\bar{W}_{ij} q_{ij}) In_2 + (\bar{W}_{ij} r_{ij})] \quad (8)$$

Where, the overall output *out* is a linear combination of the consequent parameters when the values of the premise parameters are fixed.

It can be observed that the ANFIS architecture has two adaptive layers: Layers 1 and 4. Layer 1 has modifiable parameters $\{\sigma_i, c_i\}$ and $\{\sigma_j, c_j\}$ related to the input MFs. Layer 4 has modifiable parameters $\{p_{ij}, q_{ij}, r_{ij}\}$ pertaining to the first-order polynomial. The task of the learning algorithm for this ANFIS architecture is to tune all the modifiable parameters to make the ANFIS output match the training data. Learning or adjusting these modifiable parameters is a two-step process, which is known as the hybrid learning algorithm (Jang, 1993). In the forward pass of the hybrid learning algorithm, the input membership function parameters are held fixed, node outputs go forward until Layer 4 and the output membership function parameters are identified by the least squares method. In the backward pass, the output membership function parameters are held fixed, the error signals propagate backward and the input

membership function parameters are updated by the gradient descent method.

Data and Forecast Performance Measures

Iran's agricultural products export revenue is modeled as a function of past values. Clearly, this has the shortcoming that our models are somewhat naive from the perspective of theoretical macroeconomics. However, there is a large body of literature in economics suggesting that very parsimonious models, such ARIMA model, perform better than more complex models, at least from the perspective of forecasting (Chen *et al.*, 2001). Iran's yearly agricultural products export revenues time series for the period 1974-2010 have been obtained from the website of Central Bank of Iran (www.CBI.ir). The measures like R^2 , MAD, and RMSE were use to compare the forecasting performance of various models.

RESULTS AND DISCUSSION

ARIMA Agricultural Export Revenues Forecasting

For ARIMA model, the degree of integration (d), autoregressive (p) and moving average (q) were identified by Augmented Dickey-Fuller (ADF), correlation and partial correlation diagrams, respectively. Indeed, the Schwartz-Bayesian criterion was used for identification of lag number. Figure 2 represents the results of ADF test for agricultural products export revenues and the forecasting performance of Iran's agricultural products export revenues obtained by the ARIMA model is shown in Table 1.

The left side of Table 1 demonstrates the out-sample fitness of the best designed structures of ARIMA models for forecasting 1, 2, and 4 years ahead of Iran's agricultural products export revenues in comparison with the actual observations. And its right side

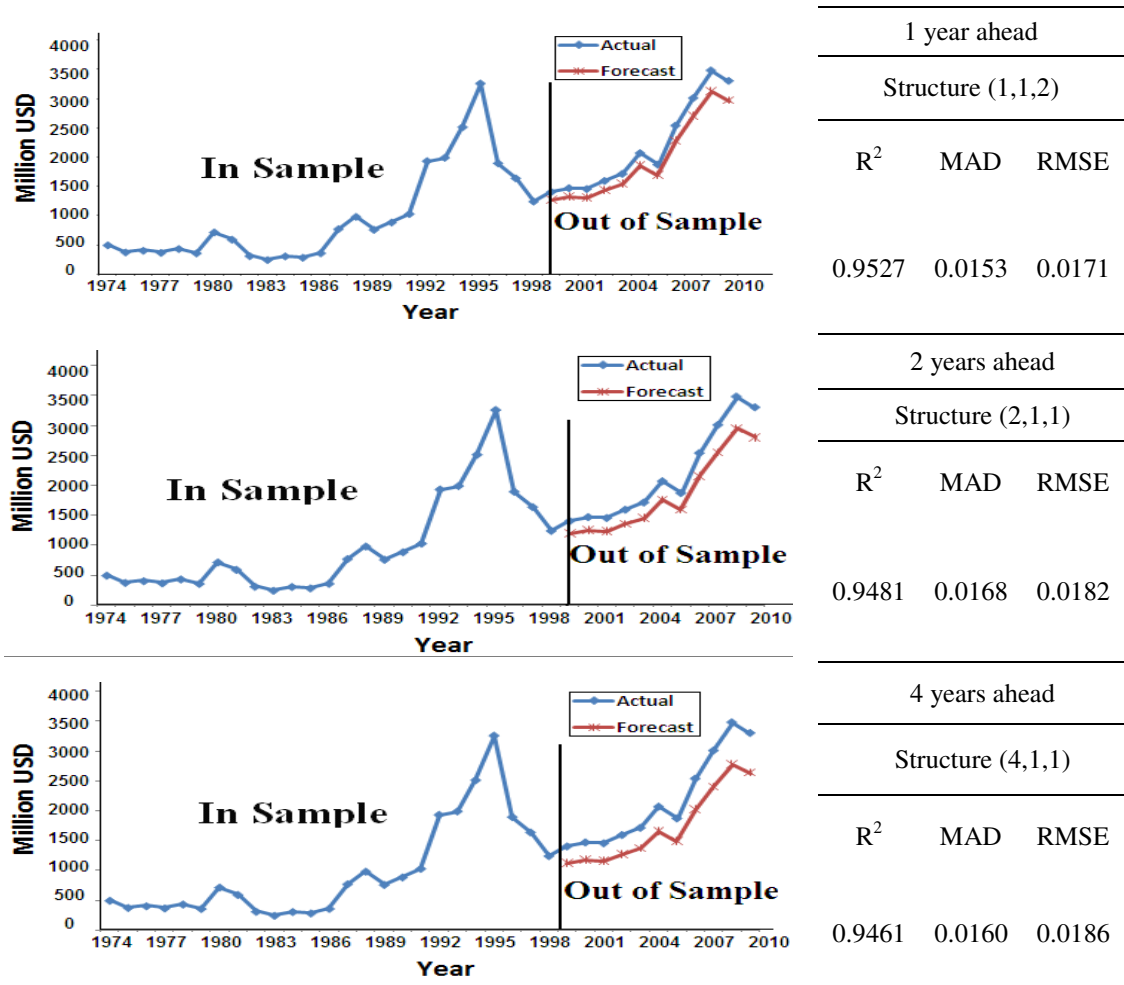

Figure 2. Results of ADF for unit root test. Source: Research findings

Table 1. Best designed architectures of ARIMA model.

Unit root tests for variable EXRVE				
The Dickey-Fuller regressions include an intercept but not a trend				
37 observations used in the estimation of all ADF regressions.				
Sample period from 1974 to 2010.				
	Test Statistic	LL ^a	AIC ^b	SBC ^c
DF ^d	-3.2231	5776.6080	5858.9903	5941.3727
DF(1) ^e	-6.1114	5761.2766	5862.7094	5954.1422
ADF(2) ^f	-6.7421	5765.9451	5857.2867	5948.6282
ADF(3) ^g	-6.7963	5761.6137	5857.9584	5952.8732

95% critical value for the augmented Dickey-Fuller statistic = -3.5608

^a Maximized log-likelihood, ^b Akaike information criterion, ^c Schwarz bayesian criterion, ^d Dicky-Fuller; ^e 1st difference Dicky-Fuller, ^f 2nd difference Augmented Dicky-Fuller, ^g 3rd difference Augmented Dicky-Fuller.

presents the values of evaluation criterions corresponding to the best ARIMA structure for forecasting the considered horizons. According to the above table, the ARIMA performance to Iran's non-oil export forecasting decreases with the time horizon increscent.

ANFIS Agricultural Export Revenues Forecasting

To design the ANFIS structures, the hybrid learning algorithm was used to identify the membership function parameters of single-output, Sugeno type Fuzzy Inference System (FIS). A combination of least-squares and back propagation gradient descent methods were used for training FIS

membership function parameters to model a given set of input/output data. In Genfis1 which generates an initial Sugeno-type FIS for ANFIS training using a grid partition the gauss and gauss2 types of membership function were used for each input and linear membership function was used for output. Also, 3 and 4 numbers of membership functions were used for each input. The forecasting performance of Iran's agricultural products export revenues obtained by the ANFIS model is shown in Figure 3.

The left side of Figure 3 demonstrates the train and test fitness of the best designed structures of ANFIS models for forecasting 1, 2, and 4 years ahead of Iran's agricultural products export revenues in comparison with the actual observations. And its right side

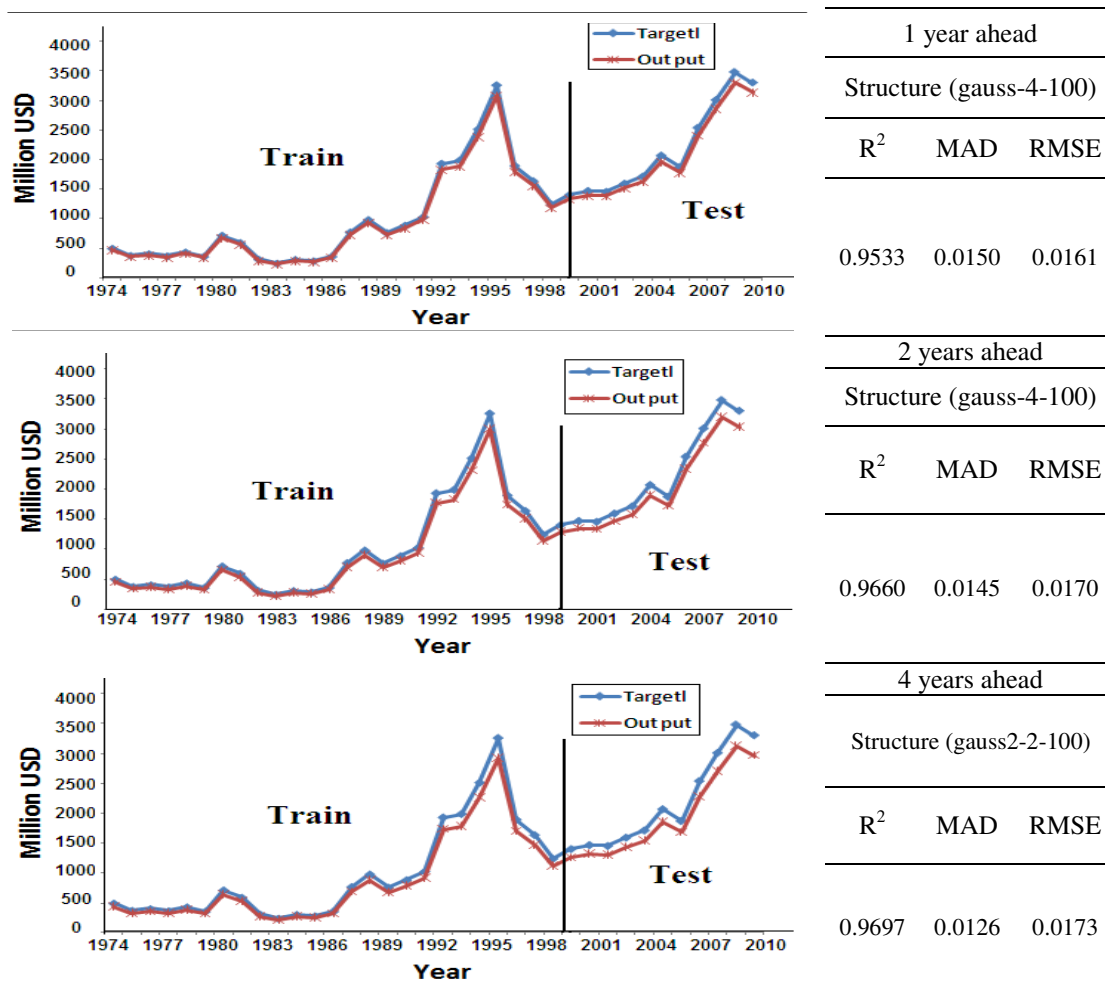

Figure 3. Best designed architectures of ANFIS model. Source: research findings

**Table 2.** Comparison of ANFIS and ARIMA performance.

Horizon(s)	C_{ANFIS}/C_{ARIMA}		R^2	MAD	RMSE
	Structure				
	ANFIS	ARIMA			
1 year ahead	gauss-4-100	(1,1,2)	1.001	0.980	0.942
2 years ahead	gauss-4-100	(2,1,1)	1.019	0.863	0.934
4 years ahead	gauss2-2-100	(4,1,1)	1.025	0.788	0.930

Source: Research findings, Note: The value of R^2 , MAD , and $RMSE$ are divided using the formula of C_{ANFIS}/C_{ARIMA} , by which if the values of MAD and $RMSE < 1$, while the value of $R^2 > 1$, the best fit model is ANFIS.

presents the values of evaluation criterions corresponding to the best ANFIS structure for forecasting the considered horizons. According to the above table, the ANFIS performance to Iran's agricultural products export revenue forecasting decreases with the time horizon increment.

ANFIS vs. ARIMA Models to Iran's Agricultural Export Revenues Forecasting

In order to compare the performance of the considered linear and nonlinear models, we divided the values of forecast evaluation criterions of ANFIS to ARIMA model per each horizon. Table 2 demonstrates the results of these comparisons:

According to the above Table 2, the ANFIS nonlinear model forecasting performance was better in contrast with the ARIMA linear model because: (1) the RMSE and MAD divided are less than 1 and (2) the R^2 divided is more than 1. Therefore, the ANFIS model is an effective way to improve the forecasting accuracy of Iran's agricultural products export revenues.

CONCLUSIONS

Non-linear processes are usually too complicated for accurate modeling by traditional and statistical models, therefore, there is always room for alternative model types such as the data based models. The application of ANFIS as a nonlinear fuzzy neural network model and ARIMA as a linear model were compared for Iran's agricultural products export revenues forecasting. As an empirical application, the

various forecasting performance of the mentioned models for 1, 2, and 4 years ahead were compared via common forecast performance measures. The ANFIS nonlinear model forecasts were considerably more accurate than the linear traditional ARIMA model, which was used as benchmarks in terms of error measures such as $RMSE$ and MAD . On the other hand, as far as the R^2 criterion is concerned, ANFIS nonlinear model was absolutely better than ARIMA linear model. Using forecast evaluation criteria, it has been demonstrated that ANFIS nonlinear model outperforms ARIMA model. Therefore, the ANFIS model is an effective way to improve the forecasting accuracy of Iran's agricultural products export revenues.

REFERENCES

1. Box, G. E. P. and Jenkins, G. M. 1970. *Time Series Analysis: Forecasting and Control*. Holden-Day, San Francisco, 199-201
2. Chen, X., Racine, J. and Swanson, R. N. 2001. Semiparametric ARX Neural Network Models with an Application to Forecasting Inflation. *IEEE Transactions on Neural Networks*, **12** (4): 674-683.
3. Economic Time Series Database, Economic Research and Policy Department, Central Bank of Iran (CBI), 2005-2010.
4. Fahimifard, S. M. 2008. The Comparison of Artificial-neural and Auto-regressive Models for Forecasting Agricultural Product Price of Iran.

- Dissertation for MSc. Degree, Agricultural Economics Engineering, University of Zabol, Iran.
5. Fahimifard, S. M., Salarpour, M., Sabouhi, M. and Shirzady, S. 2009. Application of ANFIS to Agricultural Economic Variables Forecasting Case Study: Poultry Retail Price. *J. Artificial Intelligence*, **2(2)**: 65-72.
 6. Gencay, R. 1999. Linear, Non-linear and Essential Foreign Exchange Rate Prediction with Simple Technical Trading Rules. *J. Int. Econ.*, **47**: 91-107.
 7. Haofei, Z., Guoping, X., Fagting, Y. and Han, Y. 2007. A Neural Network Model Based on the Multi-Stage Optimization Approach for Short-Term Food Price Forecasting in China. *Expert Syst. Appl.*, **33**: 347-356.
 8. Hann, T. H. and Steurer, E. 1996. Much Ado about Nothing? Exchange Rate Forecasting: Neural Networks vs. Linear Models Using Monthly and Weekly Data. *Neurocomputing*, **10**: 323-339.
 9. Ho, S. L. and Xie, M. 1998. The Use of ARIMA Models for Reliability and Analysis. *Computers Industrial Engineering*, **35**: 213-216.
 10. Ince, H. and Trafalis, T. B. 2005. A Hybrid Model for Exchange Rate Prediction. Online at: <http://www.sicencedirect.com/> [20 May 2008].
 11. Iran Agribusiness Report Q2. 2010. *New Market Analysis Released*. Pr-inside.com. 2010-03-29. <http://www.pr-inside.com/iran-agribusiness-report-q-r1801810.htm>. Retrieved 2011-09-22.
 12. Jang, J. S. R. 1993. ANFIS: Adaptive-network-based Fuzzy Inference Systems. *IEEE Transact. Syst. Man Cybernetics*, **23(3)**: 665-685.
 13. Kalogirou, S. A. 2003. Artificial Intelligence for the Modeling and Control of Combustion Processes: A Review. *Progress Energy Combustion Sci.*, **29**: 515-566.
 14. Kamwa, I. Grondin, R. Sood, V. K. Gagnon, C. Nguyen, V. T. and Mereb, J. 1996. Recurrent Neural Networks for Phasor Detection and Adaptive Identification in Power System Control and Protection. *IEEE Transact. Instrumentation Measurement*, **45(2)**: PP: 657-664.
 15. Makridakis, S. Wheelwright, S. C. and Hyndman, R. J. 1998. *Forecasting: Methods and Applications*. John Wiley and Sons, New York, 89-103.
 16. Racine, J. S. 2001. On the Nonlinear Predictability of Stock Returns Using Financial and Economic Variables, forthcoming. *J. Business Econ. Statistics*, **19(3)**: 80-382.
 17. Sugeno, M. 1985. *Industrial Applications of Fuzzy Control*. Elsevier Science Publisher Co, Elsevier Science Ltd; First edition (December 1985), PP: 201-202.
 18. Wang, Y. M. and Elhag, T. 2008. An Adaptive Neuro-fuzzy Inference System for Bridge Risk Assessment. *Expert Syst. Appl.*, **34(4)**: 3099-3106.
 19. Wu, B. 1995. Model-free Forecasting for Non-linear Time Series (With Application to Exchange Rates). *Computational Statistics Data Analysis*, **19**: 433-459.
 20. Zhang, G. and Hu, M. Y. 1998. Neural Network Forecasting of the British Pound/US Dollar Exchange Rate. *Int. J. Manage. Sci.*, **26(4)**: 495-506.



کاربرد سیستم استنتاج عصبی-فازی تطبیقی (ANFIS) در پیش بینی درآمدهای صادرات محصولات کشاورزی (مطالعه موردی بخش کشاورزی ایران)

س.ا. محدث و س.م. فهیمی فرد

چکیده

در این مطالعه کاربرد سیستم استنتاج عصبی-فازی تطبیقی (ANFIS) در پیش بینی سه افق (یک، دو و ۴ سال) آتی صادرات محصولات کشاورزی ایران با مدل خودرگرسیون میانگین متحرک انباشته (ARIMA) بعنوان رایج ترین مدل خطی پیش بینی در اقتصادسنجی مقایسه شد. برای این منظور درآمدهای صادرات محصولات کشاورزی برای دوره ۱۹۵۹ تا ۲۰۱۰ و معیارهای کارایی پیش بینی از جمله ضریب نیکویی برازش (R^2)، میانگین قدرمطلق انحرافات (MAD) و ریشه میانگین مربع انحرافات (RMSE) مورد استفاده قرار گرفت. نتایج ارزیابی کارایی مدل ها نشان داد که داده های آزمون پیش بینی شده مرتبط با ساختارهای طراحی شده مدل ANFIS، در مقایسه با داده های پیش بینی شده خارج از نمونه مدل ARIMA، از تطابق بیشتری با داده های واقعی برخوردار می باشند. بنابراین مدل غیرخطی ANFIS بر مدل خطی ARIMA در تمامی افق های مورد نظر برتری دارد.