

Efficient Solar Air Heater with Perforated Absorber for Crop Drying

A. Zomorrodian^{1*}, and M. Barati¹

ABSTRACT

Outdoor experiments on a once-through single glazed solar air heater with perforated metal absorber plate were conducted to determine the practical effect of absorber plate porosity as well as suction air flow rate on the collector thermal efficiency and its total pressure drop. Three aluminum absorber plates were made perforated by drilling circular holes with different diameter/pitch ratios in square layout. A fan was employed at the top of the collector to suck ambient air from the bottom side through absorber plate perforations. The flow channel was designed such that uniform air flow over the entire absorber plate area could be achieved. Five levels of air mass flow rates (0.0065 to 0.0321 kg m⁻² s⁻¹) were adopted. Pressure drop across the apparatus was measured. The inlet air was preheated by short wavelength radiation absorbed by the cover as well as the long wavelength emission by the absorber prior to catching the heat from transpired absorber plate. A maximum thermal efficiency of 84% could be achieved for the most part of the porous absorber plate at the highest air mass flow rate. The collector with minimum porosity showed a maximum pressure drop. In some experiments, the glass cover was removed to determine the outdoor effect of glazing. Comparing the performance of the collector with and without glazing showed that the unglazed collector was about 25% less efficient than the glazed one at the same overall operating conditions. This reduction can be attributed to high top radiative and convective heat losses for the unglazed collector at the outdoor conditions. The pressure drop for the uncovered collector showed a lower magnitude in comparison to the covered one. The inlet air passes and heats up (21-59°C above the ambient) through the solar collector, therefore the fresh and clean hot air can be continuously supplied for many purposes such as solar drying system.

Keywords: Air solar collector, Drying, Transpired absorber.

INTRODUCTION

For supplying cheap and clean hot air for space heating and for crop drying, solar air heaters can be simply employed [11]. Once-through air solar collectors operating in an open-loop system have been specifically employed for crop drying applications [10, 17]. Solar air heaters are inherently low in thermal efficiency due to low heat capacity and low thermal conductivity of the air in comparison to the liquid type solar collectors [7]. Many researchers have tried to enhance the efficiency of the solar air heaters through

providing an intimate heat transfer between air and absorbing media. Among different designs, matrix and transpired absorber type solar air heaters are the most efficient types [4, 5, 11, 13, 6, 14, 9, 15, 17, 8, 1].

However the matrix type solar air heaters are bulky and heavy compared to the transpired plate absorber type. In the latter, the absorber may be composed of a sheet of thick black cloth [16] or a perforated metallic or plastic plate [9]. Under laboratory test conditions, a high thermal performance has been reported for unglazed collector [15, 9] as well as for the glazed one [16, 17].

¹ Department of Agricultural Engineering, Shiraz University, Shiraz, Islamic Republic of Iran.

* Corresponding author; e-mail: zomorod@shirazu.ac.ir



Unglazed Transpired-plate air solar Collectors (UTC) have been the subject of many investigations during the last two decades. They are light, cheap, simple in construction and easy in application[14, 9, 1]. Kutscher *et al.* (1993) reported temperature rise between 12°C t and 36°C and efficiency of 50% to 80% for UTCs.

The operation of these solar air heaters relies on formation of a very thin and stable boundary layer on the absorber plate surface due to the parallel flow of a glazing air stream over the plate which is subject to a uniform suction. Absorber plates of slotted type perforations [9] as well as circular hole perforations [15] have been studied both numerically and experimentally.

In spite of higher thermal performance reported for UTC, however, in an outdoor condition test, the air stream is not going to blow always parallel and invariable direction with respect to the plate and its perforation, so the outdoor performance of the unglazed solar air heaters is subject to many such variations as air stream velocity, blowing direction, ambient and sky temperatures, incident solar radiation variations, etc.

To cut the radiation losses to a minimum and to reduce the high effect of air stream blowing and blowing direction, the present work was conducted on a single glazed metallic transpired absorber solar air heater for outdoor conditions. In order to investigate the effect of porosity of the absorber plate and air mass flow rate on the collector thermal performance, collectors with different porous absorber plates at different air mass flow rates were tested.

MATERIALS AND METHODS

To conduct the outdoor experiments a test

rig was designed, fabricated and put to implication. The rig consisted of a single glazed solar air heater with perforated aluminum sheet absorber, an air diffuser, an air reducer, air ducting system, a blower with a damper, a portable stand with inclination altering facilities, devices for measuring air mass flow rate, thermal sensors connected to a data acquisition system with its associated software for recording and monitoring the absorber and air temperatures, an accurate solarimeter for on line reading and recording the solar radiation intensities throughout the test and a precise inclined manometer for measuring the static pressure fluctuations across the collector.

The main frame of the collector was made of pressed wood (10 mm thickness). A sheet of glass, 4 mm in thickness, was used to cover the collector. Three sheets of aluminum plate, 1.25 mm in thickness, with different porosities, (P), different hole diameter/pitch ratios between two successive holes, (Φ), in square layout, Table 1, and matt black color painted were employed as perforated absorber plates. Effective surface area for each absorber and glass cover were 1.06 m×0.70 m (Figure 1).

$$P (\%)= [(Total\ hole\ surface\ area)/(Effective\ absorber\ surface\ area)]\times 100 \tag{1}$$

To maintain a uniform air flow through the absorber plate, along and across the air flow direction, the cross section area between absorber and cover was gradually reduced along the air flow direction (Figure 2), [5]. Collector body was thoroughly insulated by two thick sheets of glass wool (at least 50 mm in thickness), (Figure 3).

Twenty thermal sensors with ±0.5°C accuracy (PT100) were employed to measure the air and the absorber temperatures at different locations: four for

Table 1. Technical specifications of perforated absorber plates.

Plates	P (%)	Φ (Decimal)	Hole dia. (mm)	Pitch (mm)
1	0.785	0.10	2	20
2	1.786	0.15	3	20
3	3.314	0.20	2	10

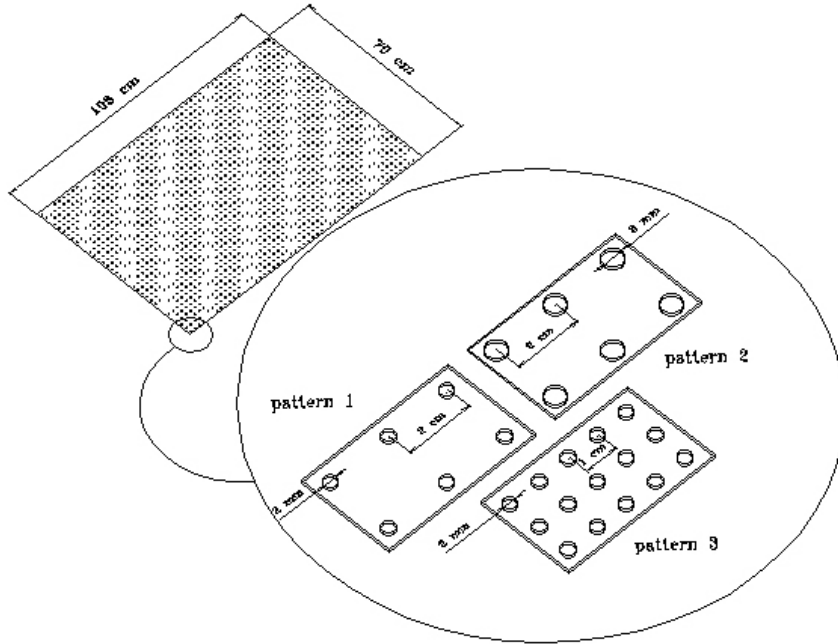

Figure 1. Absorber plate porosities and their arrangements.

inlet air, four for outlet air, five for air just leaving the absorber (5 symmetrical points) and five for the absorber plate (5 symmetrical points, three in the flow direction and two across flow direction). The tips of the thermal sensors were properly shielded against the radiation (Figure 4).

To provide different air flow rates for different tests, a centrifugal blower was employed in the downstream and for maintaining a specific air flow rate, an adjustable damper was used at the blower outlet. Three appropriate orifice plates (14, 24 and 30 mm dia.) with D and $D/2$ tapping were used to measure the air mass flow rate, using Equation (2) [12].

$$\dot{m} = CE\varepsilon\pi/4 d^2 \sqrt{2\Delta P \times \rho} \quad (2)$$

Where:

- \dot{m} = Air mass flow rate (kg s^{-1}),
- C = Coefficient of discharge,
- E = Velocity of approach factor = $(1 - \beta^4)^{1/2}$,

- ε = Expandability factor,
- d = Orifice diameter (m),
- ΔP = Pressure drop across the orifice plate (kPa),
- ρ = Density of air (kg m^{-3}),
- $\beta = D/d$,
- D = Pipe diameter (m).

A precise inclined manometer employed used to measure the static pressure across the orifice plates. An accurate silicon type solarimeter (Casella, S. no. 047025, range 0–2000 W, sensivity=1 mV for $1\text{W}^{-1} \text{m}^{-2}$) was also applied to measure and record the incident solar radiation throughout the tests.

The rig was erected in Agricultural Engineering Department, College of Agriculture, Shiraz University. The tests were run in three replications during the period of July to September 2004 on very clear sky days from 11 till 14 hours daily (average insolation was 1020 W m^{-2} during this period, $\pm 50 \text{ W m}^{-2}$ on collector surface). Local altitude was 29.5 degrees, therefore

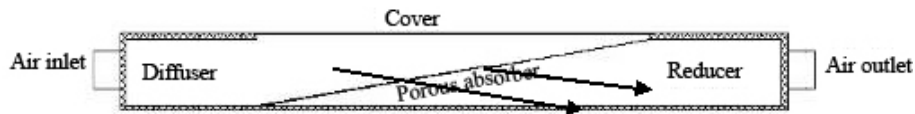

Figure 2. Single glazed solar air heater with perforated absorber.

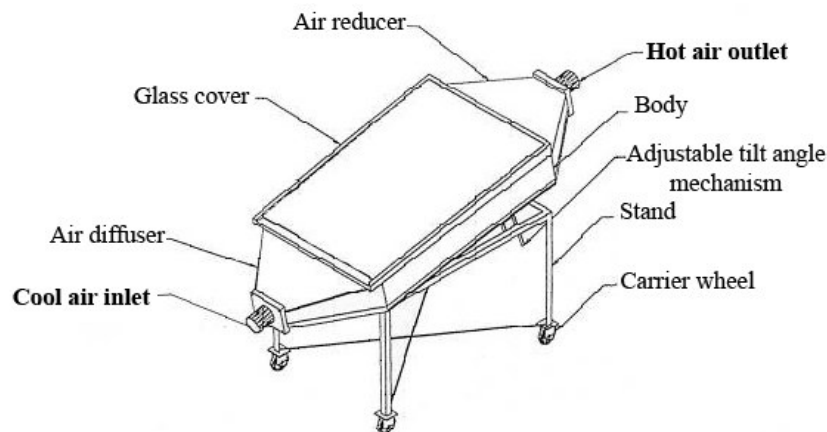

Figure 3. Solar air heater and its attachments.

the collector was set 45 degrees towards the south [7]. For each perforated absorber plate, five levels of air mass flow rates: 0.0065, 0.014, 0.022, 0.026 and 0.0312 kg m⁻² s⁻¹ were adopted. To evaluate the effect of glazing for outdoor tests, a couple of experiments were also conducted on unglazed solar air heater with two of the absorber plates 2 and 3 at the same air mass flow rates.

To evaluate the outdoor collector performance at different air flow rates for each of the absorber plates, three experiments were run and the mean of this set taken as a single point of the experimental value. Variations in local ambient air temperature, solar radiation intensity and air stream velocity were minor during the course of experiments (11-14 hours daily). The rig was switched on 0.5

hour prior to recording the data to make some minor adjustments and to let the system reach the steady state conditions.

RESULTS AND DISCUSSION

Several equations have been used by researchers to evaluate the solar air heater efficiency. For cases in which the ambient air temperature is the same as collector inlet air temperature (once-through collector), the following equation can be used [3].

At highest air mass flux of 0.0321 kg m⁻² s⁻¹ the present porous absorber solar air heater showed very high instantaneous efficiencies of 0.778, 0.757 and 0.840 for plates 1, 2 and 3 respectively, during the experimental time of 11-13 on clear days of June to September, not previously reported.

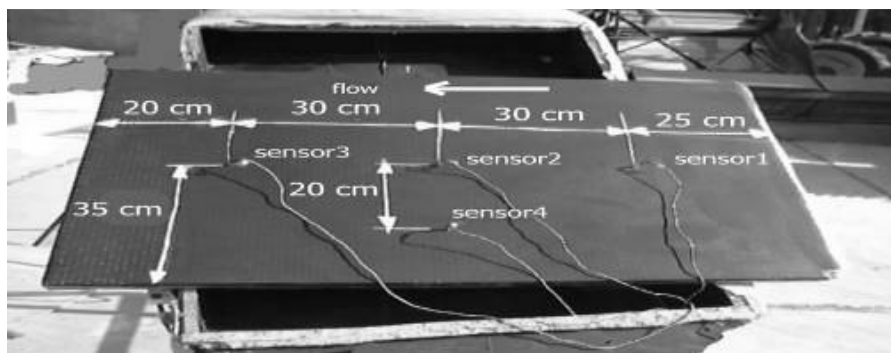

Figure 4. Location of sensors on perforated absorber plate.

$$\eta = \left(\frac{m}{A} \right) c_p \left(\frac{T_{out} - T_{in}}{G} \right) \quad (3)$$

Where: η = Solar air heater efficiency,

m/A = Air mass flux ($\text{kg m}^{-2} \text{s}^{-1}$),
 A = Collector surface area (m^2),
 c_p = Specific heat of the air ($\text{J kg}^{-1} \text{ }^\circ\text{C}^{-1}$),
 T_{out} = Outlet air temperature ($^\circ\text{C}$),
 T_{in} = Inlet air temperature ($^\circ\text{C}$),
 G = Incident solar radiation (W m^{-2}).

The inlet air was preheated by short wavelength radiation absorbed by the cover as well as the long wavelength emission by the absorber prior to catching the heat from the transpired absorber plate.

The overall results showed clearly that for the three different perforated absorber plates, the collector performance increases with an increase in air mass flux. At low and medium air flow rates the increasing rate is very significant whereas this trend continues at higher flow but with a diminishing rate (Figure 5). It can be concluded that at lower air flows the convective heat transfer coefficient between absorber plate and cooling air has a lower order of magnitude which results in a higher absorber surface temperature. Higher absorber surface

temperature boosts the convective and radiative top heat losses. These results demonstrate a very good agreement with many other researcher investigations [5, 2, 17].

Due to low heat capacity of air, a low temperature difference between cooling air and absorber plate which is caused at a higher air mass flux, collector efficiency increases very slowly at high air flow rates. Therefore, an accurate justification needs to be made between blower power and collector efficiency rise at higher air flow rates. Moreover, for once-through solar air heaters, the outlet air temperature decreases at high air flows. This may be a decision point for choosing a low and medium range of air flow rate rather than a higher one, especially in such cases as crop drying applications.

At the highest air mass flux of $0.0321 \text{ kg m}^{-2} \text{ s}^{-1}$, the present porous absorber solar air heater showed very high efficiencies of 0.778, 0.757 and 0.840 for plates 1, 2 and 3 respectively, not reported so far.

Referring to Figure 5, solar air heater with absorber plate of less perforations no.1 (Porosity= 0.785%) yielded a higher performance in comparison to more perforated absorber plate no. 2 (Porosity= 1.767%) at full range of air mass flux. Tracing the absorber plate temperatures along the absorber (in air flow direction), (Figure 6), revealed that temperature variations along the absorber plate no. 1 was much less than that of plate no. 2 which means that the temperature of plate 2 was more and non-uniformly distributed especially at the air exit due to weaker heat transfer rate. Beside this, the hole diameter in plate 2 was wider than that in plate 1 with the same pitch distance which resulted in passing the cooling air more effectively from lower part of the absorber plate no. 2 thus, keeping a non-uniform temperature distribution along the plate and higher plate temperature at the upper part of the absorber surface (more convective and radiative heat losses). On the other hand, heat transfer coefficient for the wider hole was less than

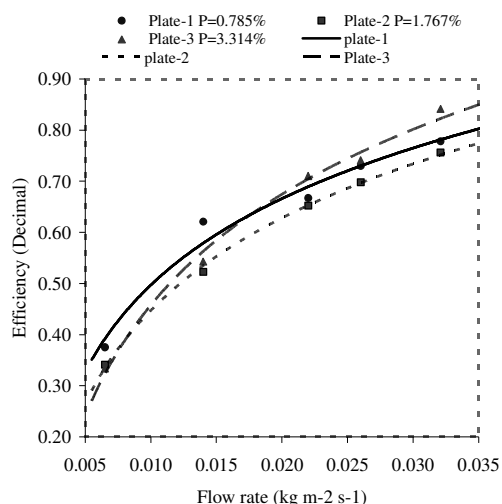

Figure 5. Effect of cooling air flux on collector efficiency for different perforated absorbers.

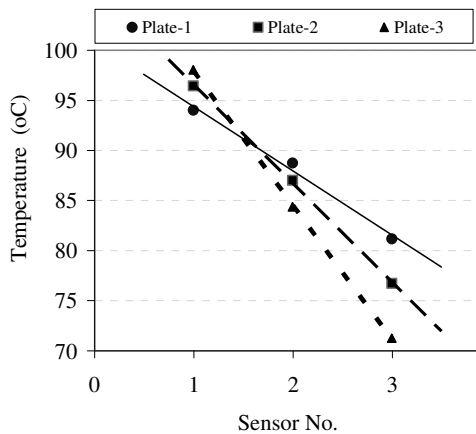

Figure 6. Absorber temperature variations along the absorber plates: Sensor 1, upper part of the absorber near the air outlet, Sensor 2, just at the middle of the absorber and Sensor 3, lower part of the absorber near the air inlet.

that for a tighter one. That is why the surface temperature of plate 2 was normally greater than plate 1. Absorber plate temperature variations across the absorber plates were not significant .

Comparing collector with plate 1 and that equipped with plate 3 showed that the former was the most efficient, at higher air mass flux, whereas the collector with plate 1

was the best at low air flow rate (Figures 5 and 7). At low air flow the least porous absorber (plate no. 1) showed a more uniform temperature distribution and efficient heat transfer throughout the absorber plate. Therefore, the absorber surface received enough cooling effect and the overall heat losses were kept low. But at low air flow the most porous absorber (plate no. 3) did not show a reasonable performance because the air could freely pass through the very frequent holes at the lower part of the plate and the upper part of the absorber (near the exit) faced with air flow shortage to be cooled effectively. It can be deduced that the cooling effect of air through small and more frequent holes of the most porous absorber plate was very significant and played an important role at higher air mass flux. It can be also concluded that for increasing the porosity index to have an efficient porous absorber solar air heater at high air flow rates, it would be more convenient to increase the number of holes with small diameter rather than small number of holes with large diameters in the absorber plates.

To find the effect of glazing on present transpired absorber solar collector performances for outdoor conditions,

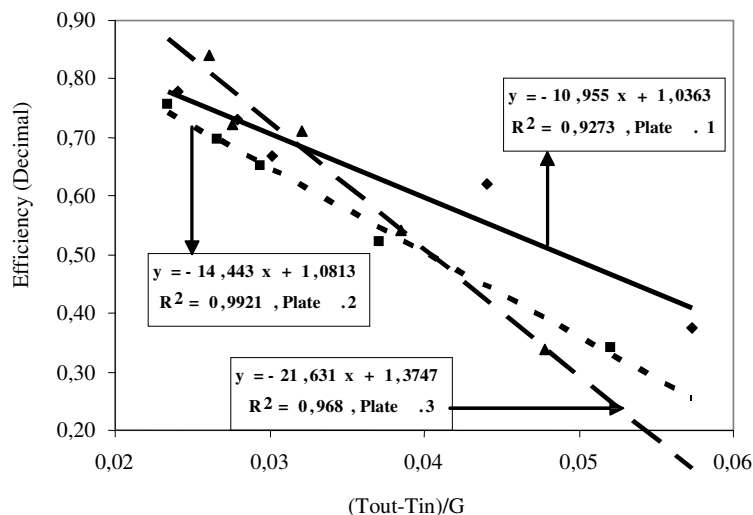

Figure 7. Variations of normalized air temperatures, $[(T_{out}-T_{in})/G, (°C m^2 W^{-1})]$, vs. collector efficiency for three absorber plates.

unglazed solar air heater with absorber plates 2 and 3 were tested and the results compared with the corresponding glazed ones (Figure 8). The results clearly show that the performance of the unglazed collectors was less pronounced than the glazed ones for the two absorber plates at full range of air mass fluxes. This reduction can be attributed to the removing collector cover, because at outdoor tests the convective and radiative heat losses had a higher order of magnitude for unglazed collector. The average efficiency for the unglazed collector showed a reduction of 27% and 23% for absorber plates 2 and 3 in comparison to the corresponding glazed collector respectively. Similar to glazed collector results, the unglazed collector with the most porous absorber showed a better performance because the numerous small holes, distributed evenly on absorber surface, kept the absorber surface temperature down and the air was able to sweep more heat from the small hole walls especially at higher air mass fluxes.

Figures 9 and 10 show the static pressure drop variations vs. air mass flow rates for glazed and unglazed solar air heater with absorber plates 2 and 3. As expected the pressure drop increased with an increase in flow rate for both the glazed and unglazed collector but at different rates. At lower air flow rate less than $0.014 \text{ kg s}^{-1}\text{m}^{-2}$ the pressure drop values were nearly the same for both absorber plates, showing minor variations.

The most porous absorber plate (plate 3) showed a mild pressure drop at the highest air flow rate (90 Pa). This fact indicated a low power consumption for running the collector at the highest thermal performance (Figure 10).

For unglazed collector the minimum value for static pressure (25 Pa) occurred at air flow rates more than $0.016 \text{ kg s}^{-1}\text{m}^{-2}$. According to the Kutscher *et al.* (1993), pressure drop across the absorber plate has to be at least 25 Pa to ensure a uniform flow and temperature distribution over the collector.

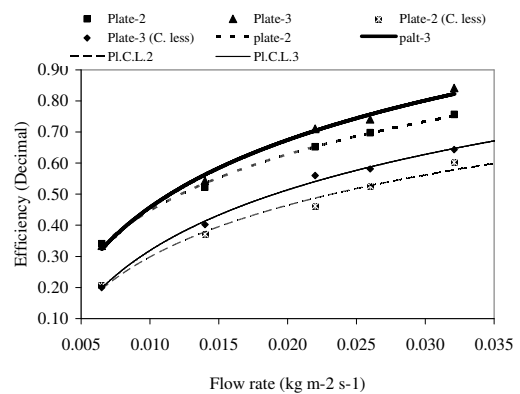

Figure 8. Unglazed and glazed performance comparison for porous absorber plate in solar air heaters. CL= C...= Unglazed.

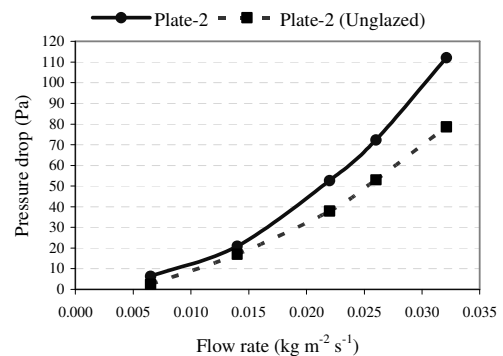

Figure 9. Static pressure drop as a function of air mass flow rate for porous absorber plate no. 2 for single glazed and unglazed collector.

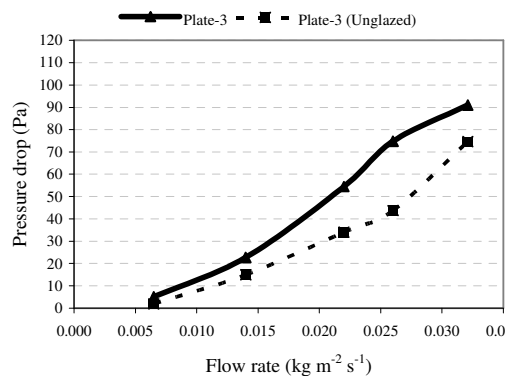

Figure 10. Static pressure drop as a function of air mass flow rate for porous absorber plate no. 3 for single glazed and unglazed collector.



CONCLUSIONS

A single glazed air solar collector with three different perforated absorber plates and under air mass flow rates of 0.0065 to 0.0321 kg m⁻² s⁻¹ was tested. A maximum thermal efficiency of 84% could be achieved for the most porous absorber plates at the highest air mass flow rate. The collector with minimum porosity showed a maximum pressure drop. In some experiments the glass cover was removed to determine the outdoor effect of glazing. Comparing the performance of the collector with and without glazing showed that the unglazed collector was about 25% less efficient than the glazed one at the same overall operating conditions. The pressure drop for the uncovered collector showed a lower magnitude in comparison to the covered one. The inlet air passes and heats up (21-59°C above the ambient) through the solar collector.

REFERENCES

1. Augustus Leon, M. and Kumar, S. 2007. Mathematical Modeling and Thermal Performance Analysis of Unglazed Solar Collector. *Sol. Energy*, **81**: 62-75.
2. Beckman, W. A., Klein, S. A. and Duffie, J. A. 1977. *Solar Heating Design*. John Wiley, New York. 200 PP.
3. Biondi, P., Cicala, L. and Farina, G. 1988. Performance Analysis of Solar Air Heater of Conventional Design. *Solar Energy*, **3**: 55-64.
4. Bliss, R. W. 1955. *Solar House Heating: A Panel*. In: "Applied Solar Energy". World Symposium. 151-158, Phoenix, Arizona, USA. 295 PP.
5. Chiou, J. P., Duffie, J. A. and El-Wakil, M. M. 1965. A Slit and Expanded Aluminum Foil Matrix Solar Collector. *Solar Energy*, **9**:73-90.
6. Choudhury, C. and Gary, H. P. 1993. Performance of Air-heating Collectors with Packed Airflow Passage. *Solar Energy*, **50(3)**: 205-221.
7. Duffie, J. A. and Beckman, W. A. 1991. *Solar Engineering of Thermal Processes*. John Wiley and Sons. New York. 918 PP.
8. Gawlik, K., Christensen, C. and Kutscher, C. 2005. A Numerical and Experimental Investigation of Low-conductivity Unglazed, Transpired Solar Air Heater. *J. Sol. Energy Eng.*, **127(1)**: 153-155.
9. Golneshan, A. A. and Hollands, K. G. T. 2000. Forced Convection Experiments on Slotted Transpired Plates. *Transaction of the Canadian Society for Mechanical Engineering*, **24(1B)**: 335-347.
10. Grupp, M., Bergler, H., Bertrand, J. P., Kromer, B. and Cieslok, J. 1995. Convective Flat Plate Collectors and Their Applications. *Solar Energy*, **55(3)**: 195-207.
11. Hamid, Y. H. and Beckman, W. A. 1971. Performance of Air-cooled Relatively Heated Screen Matrices. *J. Eng. Power*, **93**: 221-224.
12. ISO 5167, 1980. Measurement of Fluid Flow by Means of Orifice Plates, Nozzles and Venturi Tubes Inserted in Circular Cross-section Conduits Running Full. International Organization for Standardization, Switzerland.
13. Khe, C. V. and Henderson, S. M. 1975. Performance of a Matrix Solar Collector for Heating the Air. In *68th Annual Meeting of ASAE*, University of California. USA. 16 PP.
14. Kutscher, C. F., Christensen, C. and Berker, G. 1993. Unglazed Transpired Solar Collector: Heat Loss Theory. *ASME, J. Solar Eng.*, **115(3)**: 182-188.
15. Van Decker, G. W. E., Hollands, K. G. T. and Brunger, A. P. 2001. Heat-exchange Relations for Unglazed Transpired Solar Collectors with Circular Holes on a Square or Triangular Pitch. *Solar Energy*, **71(1)**: 33-45.
16. Zomorrodian, A. A., and Woods, J. L. 2001. Performance Characteristics of a Transpired Solar Air Heater. *Iran Agric. Res.*, **20**: 139-154.
17. Zomorrodian, A. A., and Woods, J. L. 2003. Modeling and Testing a New Once-through Air Solar Energy Collector. *J. Agric. Sci. Technol.*, **5**: 11-19.

هوا گرم کن خورشیدی با صرفه مجهز به صفحه جاذب مشبک برای مقاصد خشک کردن

ع. زمردیان و م. براتی

چکیده

یک گرمکن خورشیدی با پوشش تک لایه ای که دارای صفحه جاذب فلزی مشبک بود برای دستیابی به اثر میزان مشبک بودن صفحه جاذب و نرخ عبور هوای خنک کننده بر بازده آن و همچنین مقدار افت فشار هوا در شرایط طبیعی مورد آزمایش قرار گرفت. در روی سه صفحه جاذب از جنس آلومینیم با آرایش مربعی سوراخهای منظمی بشکل دایره تعبیه گردید بطوریکه قطر سوراخهای ایجاد شده و همچنین فاصله آنها نسبت بهم متفاوت بودند. یک مکنده هوا در سمت بالای جمع کننده نصب گردید تا بتوان با طراحی صحیح کانال عبور هوای محیط را از درون صفحه جاذب بطور یکنواختی عبور داد. پنج نرخ عبور هوا (۰/۰۰۶۵ تا ۰/۰۳۲ کیلو گرم بر متر مربع-ثانیه) برای انجام آزمایشات انتخاب گردیدند. افت فشار هوای عبور داده شده از جمع کننده اندازه گردید. هوای وارد شده به گرمکن ابتدا توسط امواج کوتاه جذب شده توسط پوشش شفاف و امواج بلند ساطع شده توسط صفحه جاذب پیش گرم شده و سپس از صفحه مشبک جاذب عبور کرده و گرم میشود. بازده حرارتی تا ۸۴ در صد برای مشبک ترین صفحه جاذب و در بالاترین نرخ عبور هوا قابل دسترسی است. کالکتور مجهز به صفحه جاذب با کمترین تخلخل حد اکثر افت فشار را نشان داد. برای ارزیابی حضور پوشش شیشه ای و اثر آن در بازده حرارتی کالکتور خورشیدی در شرایط طبیعی در چند آزمایش پوشش مزبور برداشته و آزمایشهایی انجام گردید. نتایج نشان دادند که جمع کننده بدون پوشش بطور متوسط بازدهی حدود ۲۵ در صد کمتر از جمع کننده پوشش دار دارد که البته این کاهش را می توان بحساب افزایش تلفات حرارتی بصورت تابشی و همرفتی در کالکتور بدون پوشش گذاشت. جمع کننده بدون پوشش مقادیر کمتری از افت فشار هوا را نشان داد. هوای محیط بعد از گذر از گرمکن خورشیدی بین ۲۱ تا ۵۹ درجه سانتیگراد گرمتر از هوای ورودی می-گردد و از آنجائیکه کالکتور بصورت مدار باز کار میکند همواره میتواند هوای گرم و تازه برای مقاصد خشک کردن فراهم کند.