

## **Modeling and Testing a New Once-through Air Solar Energy Collector**

A. A. Zomorodian<sup>1</sup> and J. L. Woods<sup>2</sup>

### **ABSTRACT**

A new once-through air solar collector was modeled and tested. In this solar heater a transpired absorber was used. The cover of the collector was double glazed and consists of many slats and assembled in such a way that it formed a stair step fashion and made many slots through which inlet air was sucked into the collector. The sucked air is believed to recover part of the sort wavelength radiation absorbed by the glass sheets. Furthermore, the long wavelength emission from the transpired absorber was trapped by the double glazing cover and could also be captured by the air thus reducing total heat loss. A mathematical model was developed to predict the effects of variations in the input parameters on the collector thermal efficiency. The theoretical results showed that the thermal performance of the collector was sensitive to air flow rate, ambient temperature, solar irradiance, absorber emissivity variations, Slat length and slot height. The collector was tested under a solar simulator over a wide range of air flow rates. The experimental results were in good agreement with the theoretical values. An absorbing efficiency as high as 82% could be obtained. Since the air heater was once-through, it is very suitable for grain drying purposes.

**Keywords:** Solar air heater, Transpired absorber, Transpired cover.

### **INTRODUCTION**

Flat plate solar collectors have been in use for a very long time. The cooling fluid in such heat exchangers can be air or water; thereby the flat plate solar collector can be divided into two groups known as air solar collectors or water solar collectors (2, 5). The air solar energy collectors have been in use for different purposes, such as space heating and space cooling. Once-through solar air heaters operating in an open-loop system have been employed for industrial drying applications and they are inherently low in thermal efficiency (at most about 50%) due to low heat capacity and specific heat of air. Many efforts have been devoted by researchers to improve the thermal performance of these solar collectors [3, 4, and 6].

In order to improve the convective heat transfer coefficient between air and absorber surface, the fin-type absorber collector and the V-type corrugated absorber collector were investigated for the effects of shape and dimension of the airflow passage. Introducing fins or corrugations into the airflow path improves the convective heat transfer coefficient but these systems have a drawback due to increasing the resistance to the airflow. A number of designs that increase the contact area between the air and absorber and/ or the heat transfer coefficient have been proposed and analyzed. In these designs, porous matrix type absorbers were employed and the results reported were very promising [7].

An overlapped glass plate absorber solar air heater was originally proposed by Miller and was thoroughly investigated by Lof (1950) and Selcuk (1971). The transpired

<sup>1</sup> Assistant Professor, Farm power and Machinery Department, Shiraz University, Islamic Republic of Iran.

<sup>2</sup> Professor, Agricultural Engineering Department, Newcastle upon Tyne University, UK.

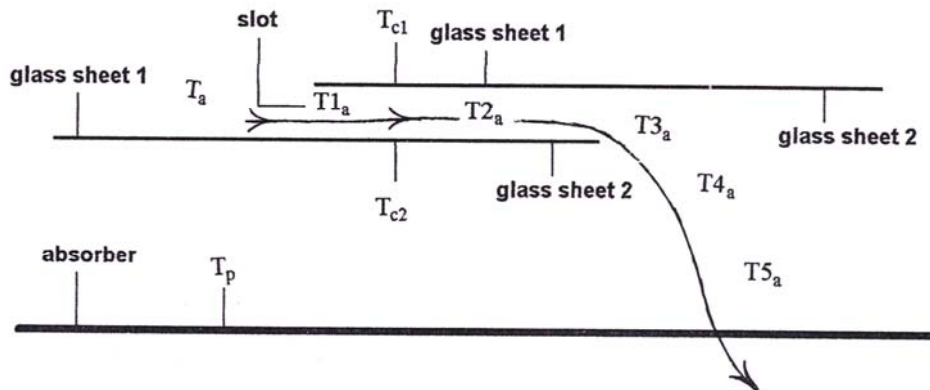

Figure 1. Schematic diagram of the collector cover and absorber.

absorbing system of this kind of air heater contained a series of single-strength glass plates arranged in stair-step fashion and separated by thin spacers. Each pane of glass was painted black at one third of the area and arranged in such a way that each black surface was beneath two clear surfaces. The daily efficiency for collecting solar energy was reported to be 30 - 60% (8 and 9).

It is envisaged that an air solar collector with a transpired cover (slatted glass sheet cover with a 100% overlap) and a transpired absorber will combine the work discussed above and produce an improved efficiency using the best features of both. This new version of solar air heater is a "once-through" type and can be used effectively for applications, such as drying [10].

## MATHEMATICAL MODELING

For the transpired absorber and the transpired cover air solar collector, a mathematical model was developed. The cover of the solar air heater was fashioned in such a way that glass sheets covered each other fully (100% overlapped, like a double glazing cover) and the slots were formed between them (Figure 1). The following simplifying assumptions were made before formulating the governing heat balance equations:

a-The collector is considered to be in a thermally steady state condition and heat flow through the glass sheet cover; absorber and insulator are one-dimensional.

b-The exposed area of the collector is large compared with its wall thickness. Therefore the edge and end losses could be neglected.

c-The airflow direction through the absorber is nearly normal to the absorber surface and downward, furthermore, air distribution through the slots and across the transpired absorber is uniform, and hence the flow develops both thermally and hydrodynamically.

d- Covers are opaque to infrared radiation; covers and absorber are at a single mean temperatures.

e- Radiative properties of materials and physical properties of air are constant.

Referring to Figure 1, and considering the airflow path through the transpired cover and transpired absorber, the following heat balance governing equations can be written [10],

1- Heat balance equations for the double glazing cover:

Heat balance equation on upper glass sheet cover:

$$SWG1 + h_{rci}(T_{c2} - T_{c1}) = h_{ca}(T_{c1} - T_a) + h_{rci}(T_{c1} - T2_a) \quad (1)$$

Heat balance equation for the lower glass sheet cover:

$$SWG2 + h_{rpc}(T_p - T_{c2}) + (1 - R_p)h_{pc}(T_p - T_{c2}) = h_{rci}(T_{c2} - T_{c1}) + h_{ci}(T_{c2} - T2_a) + h_{cl}(T_{c2} - T3) \quad (2)$$

2- Heat balance equation for the absorber:

$$SWP = h_{rpc}(T_p - T_{c2}) + mc_p(T_p - T5_a) + h_{pc}(T_p - T_{c2}) \quad (3)$$

3- Heat balance equations for the airflow:

$$\dot{m}c_p(T1_a - T_a) = R_c h_{ca}(T_{c1} - T_a) \quad (4)$$

$$\dot{m}c_p(T3_a - T1_a) = h_{ci}(T_{c1} + T_{c2} - 2T2_a) \quad (5)$$

$$\dot{m}c_p(T4_a - T3_a) = (T_{c2} - T3_a)h_{cl} \quad (6)$$

$$\dot{m}c_p(T5_a - T4_a) = R_a h_{pc}(T_p - T_{c2}) \quad (7)$$

4- Heat balance equations for useful heat gain:

$$q_u = \dot{m}c_p(T_p - T_i) \quad (8)$$

5- Equations for suggested recovery factors for the cover and absorber:

$$R_c = \frac{(\dot{m}c_p / h_{ca})}{1 + (\dot{m}c_p / h_{ca})} \quad (9)$$

$$R_p = \frac{(\dot{m}c_p / h_{pc})}{1 + (\dot{m}c_p / h_{pc})} \quad (10)$$

The above equations accompanied by properly selected correlation equations for convective and radiative heat transfer coefficients have to be solved using iteration numerical techniques to calculate the unknown

values [10]. The proper radiative properties of the material, absorber and glass sheet cover, have to be chosen [10].

## MATERIALS AND METHODS

In order to validate the theoretical model a small solar air heater was designed and fabricated. The collector main casing was made of plywood (10 mm thickness) and insulated properly at the rear and sides by polystyrene (50 mm thickness). The inner surface of the casing was painted a matt black color and the edges were sealed properly against the air leakage. A sheet of Balton Twill black thick cloth (1.00 × 0.70 m.) stretched over a supporting wide black wire mesh was used as transpired absorber. This absorber was hung firmly and diagonally inside the collector casing using the hooks and bolts. On the top side of the casing a 70 mm hole was provided to use as an outlet. The outlet was connected to the fan using connections and a combination of flexible ducting and steel pipes. Somewhere and far away enough from the outlet the orifice plates have been incorporated to measure the air mass flow rates. The upstream pipes were properly insulated by insulating materials.

The cover of the collector was made of thick Redwood and consisted of several single glass sheets arranged in a slatted fashion (Figure 2). The sheets of the cover were fully overlapped (100%) to make a double

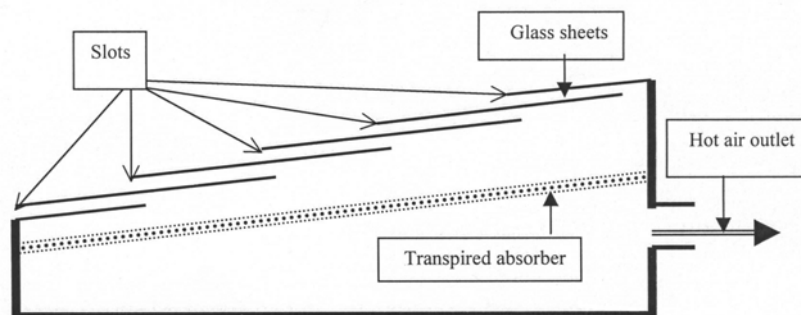

Figure 2. A simple cross section of the solar air heater.

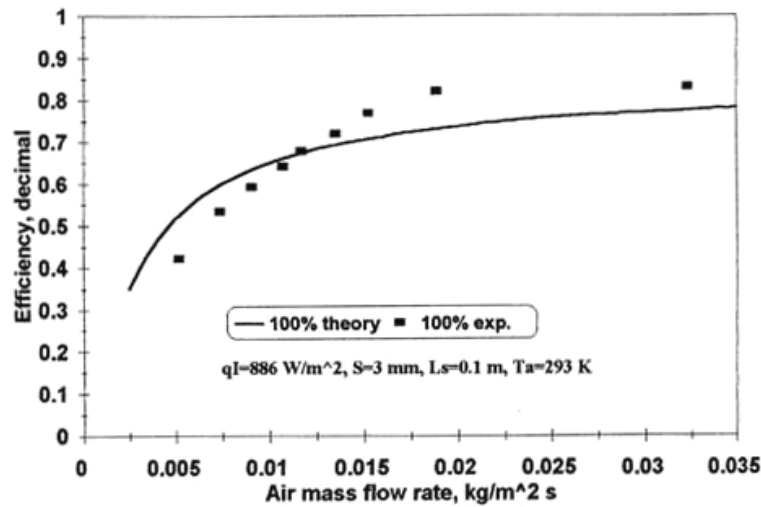

Figure 3. The relationship between air mass flow rate and absorber efficiency for 100% models (theoretical & experimental values).

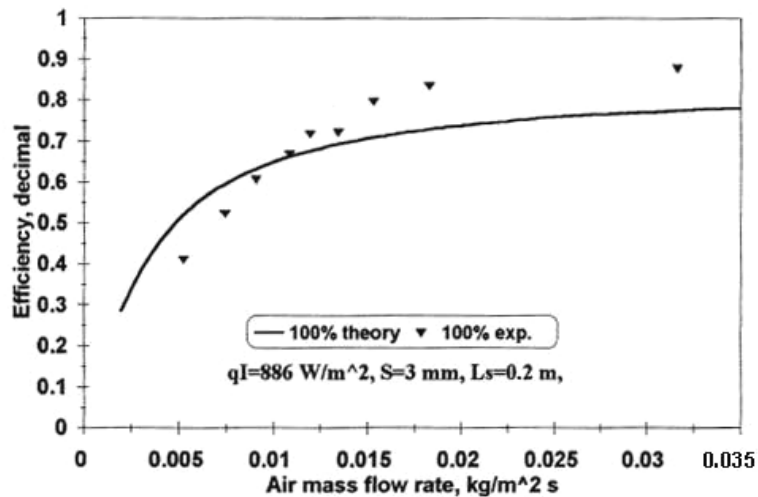
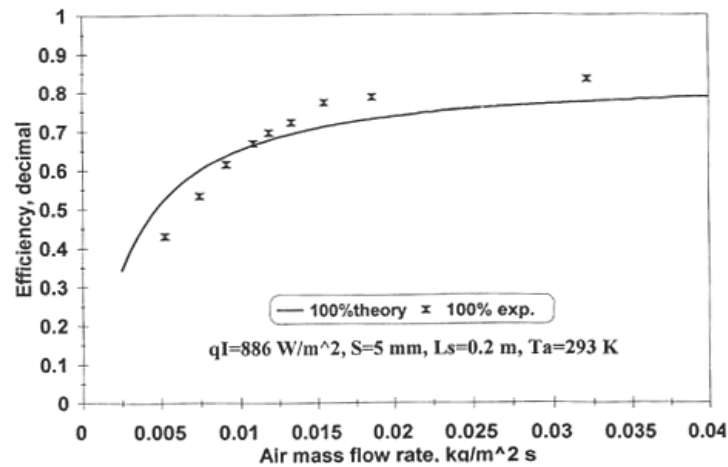

Figure 4. The relationship between air mass flow rate and absorber efficiency for 100% models (theoretical & experimental values).

glazing cover and make slats through which air was sucked into the heater. The heater was equipped with a removable cap. The cap was designed in such a way that the slot height and slat length could be easily varied. The solar heater was tested under a solar simulator with a constant solar irradiance of 886 Wm<sup>-2</sup> (average of 0.5 μm. wavelength) according to the ASHREA Standard Method

[1]. A full range of air mass flow rates of 0.004 to 0.033 kgm<sup>-2</sup> see<sup>-1</sup> with different operating conditions of slot heights (S) of 3, 5, and 9 mm and slat lengths (Ls) of 0.1 and 0.2 m were adopted to run the experiments. Finally the following relationship was used to calculate the thermal efficiency of the solar heater [5].



**Figure 5:** The relationship between air mass flow rate and absorber efficiency for 100% models (theoretical & experimental values).

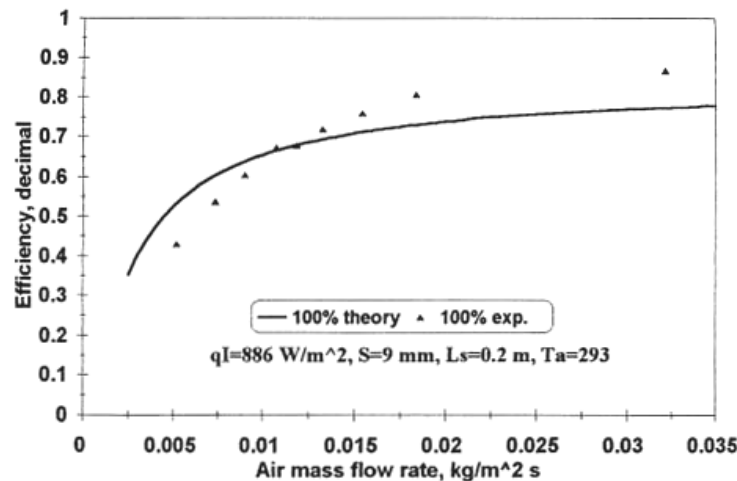

**Figure 6.** The relationship between air mass flow rate and absorber efficiency for 100% models (theoretical and experimental values).

$$eff = \frac{q_u}{q_r} \times 100 \quad (11)$$

A computer simulation technique with the aid of a computer program written in FORTRAN, was developed to be used as a tool to quantify the performance of the mathematical model. The computer program was run for different operating conditions [10]. The air temperature of the crucial points were monitored by T type thermocouples by the

aids of a data logger and a proper software.

## RESULTS AND DISCUSSIONS

In fact the fluid flow was examined for full range of air flow rates and it was found that the flow was laminar throughout the collector for full range of air mass flow rates ( $0.004$  to  $0.035 \text{ kgm}^{-2} \text{ sec}^{-1}$ ).

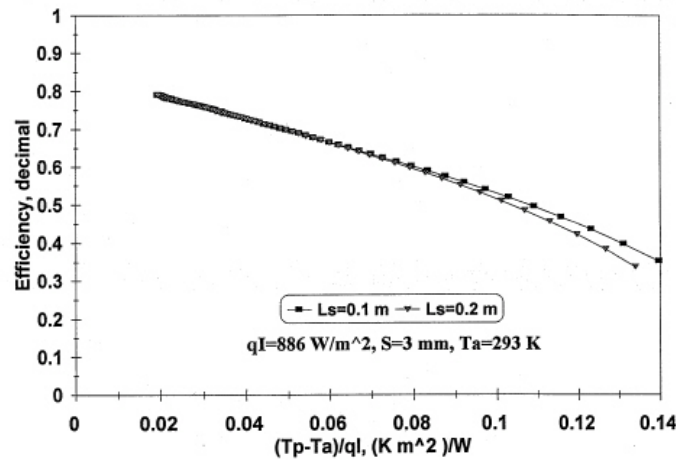

**Figure 7.** The effect of normalized temperature difference and slat length on absorber efficiency (theoretical values), hundred percent model.

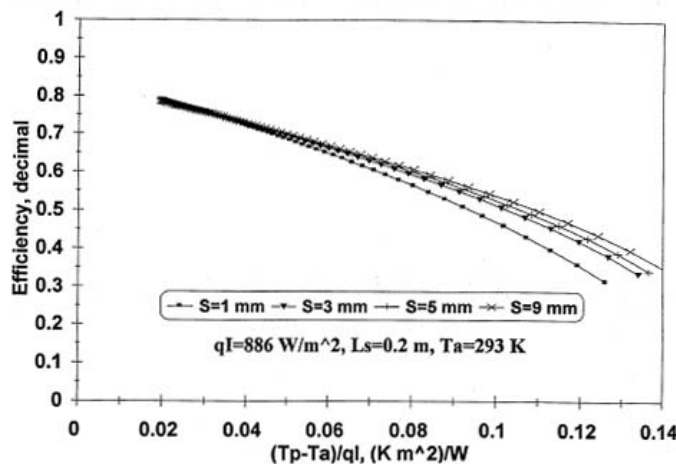

**Figure 8.** The effect of normalized temperature difference and slot height on absorber efficiency (theoretical values), hundred percent model.

The data on the mathematical model and experimental values have shown a good agreement (Figures 3 to 6). Both results indicate that the collector efficiency is sensitive to air flow rate variations but this dependency diminishes as the air flow rate increases. This is due to the fact that the buoyancy forces are quite strong and contribute a lot to the thermal losses at a low air flow rate resulting in big slopes and, as the air flow rate increases, these buoyancy forces are gradually reduced. The theoretical and experimental results showed absorber effi-

ciency as high as 82% for high air flow rates. Sensitivity analysis on the model showed very small variations when slot height and slat length were changed but the effect is more distinctive at high normalized temperature because the higher the temperature difference the more heat losses would result (Figures 7 and 8). The effect of slat length can be better argued for a shorter slat length which shows a better collector performance because the shorter the slat length the larger is the number of the slots through which air is introduced into the collector

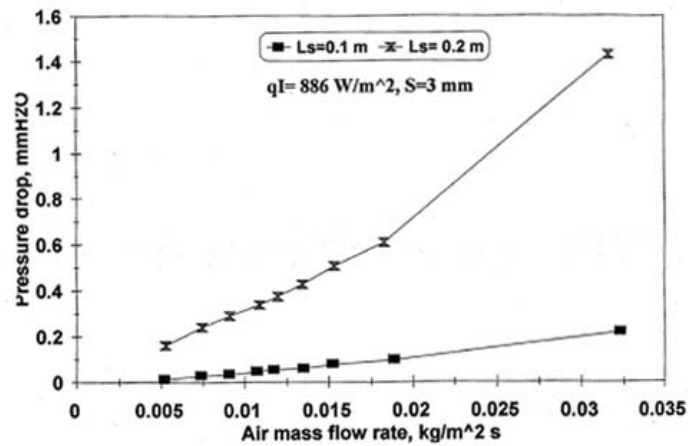

Figure 9. Experimental pressure drop across slatted glass cover at different air mass flow rates and slat length, hundred percent model.

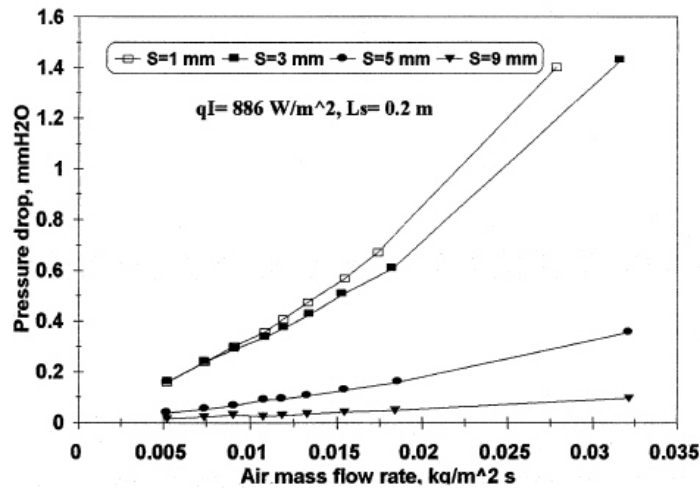

Figure 10. Experimental pressure drop across slatted glass cover at different air mass flow rates and slot height, hundred percent model.

therefore more heat otherwise lost can be recovered by sucking in air. This effect is more noticeable at a high air flow rate. Moreover the air flow is distributed more evenly through the collector as the number of slots increases and this might be another reason why the collector with a greater slot number and lower slat length shows a better thermal efficiency. Also it was found that the collector efficiency was sensitive to ambient temperature and solar irradiance variations (not shown in the Figures). The impact of slot height and slat length on pressure drop across the slatted glass sheet cover are

presented in Figures 9 and 10. As expected, the pressure drop increases sharply when slot height decreases or the slat length increases. Furthermore, the pressure drop across the slatted glass cover sheet was reasonably low, although a threshold pressure drop at the slot is necessary for the air to let in.

## REFERENCES

1. ANSI / ASHREA. Standard 93. 1986. *Methods of Testing to Determine the Thermal*



- Performance of Solar Collectors*. American Society of Heating, Refrigerating and Air conditioning Engineers, New York.
2. Bevill, B. and Brandle, H. 1968. A Solar Energy Collector for Heating Air. *Solar Energy*, **12**: 19-36.
  3. Chiou, J. P., Wakil, M. M. and Duffie, J. A. 1965. A Slit - and Expanded Aluminum foil Matrix Solar Collector. *Solar Energy*, **9**: 73-80.
  4. Close, D. J. 1963. Solar Air Heater for Low and Moderate Temperature Application. *Solar Energy*, **7**: 117-124.
  5. Duffie, J. A. and Becknam, W. A. 1991. *Solar Engineering of Thermal Process*. John and Wiley & Sons, New York.
  6. Fahmy, M. F. M., and Labib, A. M. 1991. Exact Solution of a Model for Dynamic Behavior of a Matrix Solar Air Heater. *Solar Energy*, **32**: 35-42.
  7. Hollands, K. G. T. and Shewen, E. C. 1981. Optimization of Flow Passage Geometry for Air-heating Plate Type Solar Collector. *Solar Energy Eng.*, **103**: 323-330.
  8. Lof, G. O. G. 1950. Performance of Solar Energy Collector of Overlapped - glass Plate Type. In: "Proc. of Solar Heating Symposium Open Space Heating with Solar Energy". MIT University, USA. pp. 72-86.
  9. Selcuk, K. 1971. Thermal and Economic Analysis of the Overlapped Glass Plate Solar Air Heater. *Solar Energy*, **13**: 165-191.
  10. Zomorodian, A. A. 1996. A Transpired Slatted Glass Cover Solar Air Heater. PhD. thesis, unpublished, Newcastle upon Tyne University, UK.

## NOMENCLATURE

$A_c$  Collector surface area,  $m^2$   
 $C_p$  Specific heat of air at constant pressure,  $J/kgK$

$h_{ca}$  Upper natural convective heat transfer coefficient,  $W/m^2K$   
 $h_{ci}$  In-slot convective heat transfer coefficient,  $W/m^2K$   
 $h_{cl}$  Lower convective heat transfer coefficient (plane wall jet),  $W/m^2K$   
 $h_{pc}$  Natural convective heat transfer coefficient between absorber and cover,  $W/m^2K$   
 $h_{rea}$  Radiative heat transfer coefficient between cover and surroundings,  $W/m^2K$   
 $h_{rci}$  Radiative heat transfer coefficient between overlapped cover sheet,  $W/m^2K$   
 $h_{rpc}$  Radiative heat transfer coefficient between absorber and cover,  $W/m^2K$   
 $\dot{m}$  Air mass flow rate,  $kg/m^2s$   
 $q_l$  Incident solar radiation,  $W/m^2$   
 $q_u$  Useful (extracted) thermal energy,  $W/m^2$   
 $R_c$  Cover heat recovery factor  
 $R_p$  Absorber heat recovery factor  
 $SWG1$  Short wave heat gain by upper glass sheet,  $W/m^2$   
 $SWG2$  Short wave heat gain by lower glass sheet,  $W/m^2$   
 $SWP$  Short wave heat gain by absorber,  $W/m^2$   
 $T_a$  Ambient temperature,  $K$   
 $T_c$  Cover temperature,  $K$   
 $T_{c1}$  Upper cover temperature,  $K$   
 $T_{c2}$  Lower cover temperature,  $K$   
 $T_i$  Inlet air temperature,  $K$   
 $T1_a, T2_a, T3_a$  Inside collector intermediate air temperature,  $K$   
 $T4_a, T5_a$  Inside collector intermediate air temperature,  $K$   
 $T_o$  Exit air temperature,  $K$   
 $T_p$  Absorber temperature,  $K$



## بررسی تئوری و آزمایشگاهی یک جمع کننده جدید هوایی خورشیدی با سیکل باز

ع. زمردیان و ج. ال. وودز

### چکیده

در این تحقیق یک جمع کننده جدید هوایی خورشیدی از نظر تئوری و آزمایشگاهی مورد بررسی قرار گرفت. در این گرمکن خورشیدی صفحه جاذب از نوع متخلخل مورد استفاده قرار گرفت و پوشش دو لایه ای شیشه ای این جمع کننده از تعداد زیادی قطعات شیشه ای تشکیل یافته بود که به نحوی نسبت بهم متصل شوند که یک آرایش پله ای را تشکیل دادند و شکافهائی در بین خودشان درست کردند که هوا از لابلای آنها به داخل گرمکن مکیده می شد. هوای عبور داده شده از داخل شکافها باعث خنک شدن پوشش گرمکن می گردد و بخشی از گرما که در غیر اینصورت هدر می رفت به داخل گرمکن کشیده می شود. همچنین بخشی از انرژی ساطع شده از صفحه جاذب (انرژی با طول موج بلند) توسط هوای مکیده شده به داخل گرمکن جارو می گردد. تلفیق دو عامل یاد شده باعث می شود که تلفات انرژی در کالکتور تا حد زیادی تقلیل یابد. برای پیش بینی کارآئی تئوری جمع کننده خورشیدی یک مدل ریاضی جامع نوشته شده که بتوان در آن شرایط کلی حاکم بر جمع کننده را مورد بررسی قرار داد. نتایج استخراج شده از مدل تئوری تابش انرژی خورشیدی، خواص فیزیکی صفحه جاذب، طول قطعات تشکیل دهنده پوشش دو لایه ای کالکتور و عمق شکافهائی تشکیل شده حساس است. برای بررسی اعتبار مدل پیشنهاد شده یک گرمکن ساخته و تحت شرایط کنترل شده ای مورد آزمایشات دقیق قرار گرفت. ارقام بدست آمده از نتایج آزمایشات همخوانی خوبی با آنچه مدل ریاضی پیش بینی کرده بود داشت. راندمان صفحه جاذب در آزمایشات و در تئوری حدود ۸۲ درصد گزارش گردید. این گرمکن به دلیل اینکه براساس یک سیکل باز کار می کند برای بکارگیری در خشک کن ها بسیار مناسب است.